

TAPERED ROLLER BEARINGS

METRIC DESIGN TAPERED ROLLER BEARINGS

Bore Diameter 15 – 100mm	B120
Bore Diameter 105 – 240mm	B128
Bore Diameter 260 – 440mm	B134

INCH DESIGN TAPERED ROLLER BEARINGS

Bore Diameter 12.000 – 47.625mm	B136
Bore Diameter 48.412 – 69.850mm	B150
Bore Diameter 70.000 – 206.375mm	B158

The index for inch design tapered roller bearings is in Appendix 14 (Page C26).

DOUBLE-ROW TAPERED ROLLER BEARINGS

Bore Diameter 40 – 260mm	B172
--------------------------------	------

Four-Row Tapered Roller Bearings are described on pages B334 to B339.

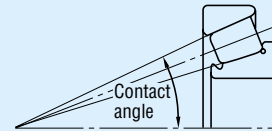

DESIGN, TYPES, AND FEATURES

Tapered roller bearings are designed so the apices of the cones formed by the raceways of the cone and cup and the conical rollers all coincide at one point on the axis of the bearing. When a radial load is imposed, an axial force component occurs; therefore, it is necessary to use two bearings in opposition or some other multiple arrangement.

For metric-design medium-angle and steep-angle tapered roller bearings, the respective contact angle symbol C or D is added after the bore number. For normal-angle tapered roller bearings, no contact angle symbol is used. Medium-angle tapered roller bearings are primarily used for the pinion shafts of differential gears of automobiles.

Among those with high load capacity (HR series), some bearings have the basic number suffixed by J to conform to the specifications of ISO for the cup back face raceway diameter, cup width, and contact angle. Therefore, the cone assembly and cup of bearings with the same basic number suffixed by J are internationally interchangeable.

Among metric-design tapered roller bearings specified by ISO 355, there are those having new dimensions that are different than the dimension series 3XX used in the past. Part of them are listed in the bearing tables. They conform to the specifications of ISO for the smaller end diameter of the cup and contact angle. The cone and cup assemblies are internationally interchangeable. The bearing number formulation, which is different than that for past metric design, is as follows:

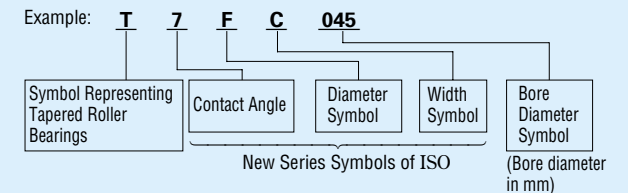

Besides metric design tapered roller bearings, there are also inch design bearings. For the cone assemblies and cups of inch design bearings, except four-row tapered roller bearings, the bearing numbers are approximately formulated as follows:

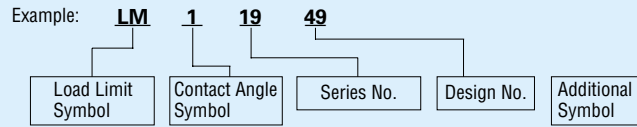

For tapered roller bearings, besides single-row bearings, there are also various combinations of bearings. The cages of tapered roller bearings are usually pressed steel.

Table 1 Design and Featured of Combinations of Tapered Roller Bearings

Figure	Arrangement	Examples of Bearing No.	Features
	Back-to-back	HR30210JDB+KLR10	Two standard bearings are combined. The bearing clearances are adjusted by cone spacers or cup spacers. The cones and cups and spacers are marked with serial numbers and mating marks. Components with the same serial number can be assembled referring to the matching symbols.
	Face-to-face	HR30210JDF+KR	
	KBE Type	100KBE31+L	The KBE type is a back-to-back arrangement of bearings with the cup and spacer integrated, and the KH type is a face-to-face arrangement in which the cones are integrated. Since the bearing clearance is adjusted using spacers, it is necessary for components to have the same serial number for assembly with reference to matching symbols.
	KH Type	110KH31+K	

TOLERANCES AND RUNNING ACCURACY

METRIC DESIGN TAPERED ROLLER BEARINGS Table 8.3 (Pages A64 to A67)

INCH DESIGN TAPERED ROLLER BEARINGS Table 8.4 (Pages A68 and A69)

Among inch design tapered roller bearings, there are those to which the following precision classes apply. For more details, please consult with NSK.

(1) J line bearings(in the bearing tables, bearings preceded by ▲)

Table 2 Tolerances for Cones(CLASS K)

Units : μm

Nominal Bore Diameter d (mm)		Δd_{mp}		V_{dp}	V_{dmp}	K_{ia}
over	incl.	high	low	max.	max.	max.
10	18	0	-12	12	9	15
18	30	0	-12	12	9	18
30	50	0	-12	12	9	20
50	80	0	-15	15	11	25
80	120	0	-20	20	15	30
120	180	0	-25	25	19	35
180	250	0	-30	30	23	50
250	315	0	-35	35	26	60
315	400	0	-40	40	30	70

Table 3 Tolerances for Cups(CALSS K)

Units : μm

Nominal Outside Diameter D (mm)		ΔD_{mp}		V_{Dp}	V_{Dmp}	K_{ea}
over	incl.	high	low	max.	max.	max.
18	30	0	-12	12	9	18
30	50	0	-14	14	11	20
50	80	0	-16	16	12	25
80	120	0	-18	18	14	35
120	150	0	-20	20	15	40
150	180	0	-25	25	19	45
180	250	0	-30	30	23	50
250	315	0	-35	35	26	60
315	400	0	-40	40	30	70
400	500	0	-45	45	34	80

Table 4 Tolerances for Effective Widths of Cone Assemblies and Cups, and Overall Width (CLASS K)

Units : μm

Nominal Bore Diameter d (mm)		Effective Width Deviation of Cone Assembly ΔT_{1s}		Effective Width Deviation of Cup ΔT_{2s}		Overall Width Deviation ΔT_s	
over	incl.	high	low	high	low	high	low
10	80	+100	0	+100	0	+200	0
80	120	+100	-100	+100	-100	+200	-200
120	315	+150	-150	+200	-100	+350	-250
315	400	+200	-200	+200	-200	+400	-400

(2) Bearings for Front Axles of Automobiles
(In the bearing tables, those preceded by t)

Table 5 Tolerances for Bore Diameter and Overall Width

Units : μm

Nominal Bore Diameter d				Bore Diameter Deviation Δd_s		Overall Width Deviation ΔT_s	
over	incl.		high	low	high	low	
(mm)	1/25.4	(mm)	1/25.4				
—		76.200	3.0000	+20	0	+356	0

The tolerances for outside diameter and those for radial runout of the cones and cups conform to Table 8.4.2 (Pages A68 and A69).

(3) Special Chamfer Dimensions

For bearings marked "spec." in the column of r in the bearing tables, the chamfer dimension of the cone back-face side is as shown on the following figure.

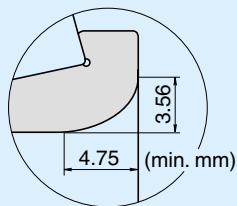

RECOMMENDED FITS

METRIC DESIGN TAPERED ROLLER BEARINGS Table 9.2 (Page A84)
Table 9.4 (Page A85)

INCH DESIGN TAPERED ROLLER BEARINGS Table 9.6 (Page A86)
Table 9.7 (Page A87)

INTERNAL CLEARANCE

METRIC DESIGN TAPERED ROLLER BEARINGS
(Matched and Double-Row) Table 9.16 (Page A93)
INCH DESIGN TAPERED ROLLER BEARINGS
(Matched and Double-Row) Table 9.16 (Page A93)

DIMENSIONS RELATED TO MOUNTING

The dimensions related to mounting tapered roller bearings are listed in the bearing tables. Since the cages protrude from the ring faces of tapered roller bearings, please use care when designing shafts and housings.

When heavy axial loads are imposed, the shaft shoulder dimensions and strength must be sufficient to support the cone rib.

PERMISSIBLE MISALIGNMENT

The permissible misalignment angle for tapered roller bearings is approximately 0.0009 radian (3').

LIMITING SPEEDS

The limiting speeds listed in the bearing tables should be adjusted depending on the bearing load conditions. Also, higher speeds are attainable by making changes in the lubrication method, cage design, etc. Refer to Page A37 for detailed information.

PRECAUTIONS FOR USE OF TAPERED ROLLER BEARINGS

1. If the load on tapered roller bearings becomes too small, or if the ratio of the axial and radial loads for matched bearings exceeds 'e' (e is listed in the bearing tables) during operation, slippage between the rollers and raceways occurs, which may result in smearing. Especially with large bearings since the weight of the rollers and cage is high. If such load conditions are expected, please contact NSK for selection of the bearings.
2. Confirm the dimension of "Abutment and Fillet Dimensions" of D_a , D_b , S_a , S_b at the time of the HR series adoption.

Bore Diameter 15 – 28 mm

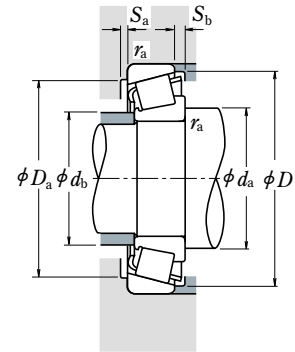
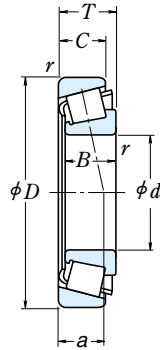

Dynamic Equivalent Load

$$P = XF_r + YF_a$$

$F_a/F_r \leq e$		$F_a/F_r > e$	
X	Y	X	Y
1	0	0.4	Y_1

Static Equivalent Load

$$P_0 = 0.5F_r + Y_0F_a$$

When $F_r > 0.5F_r + Y_0F_a$, use $P_0 = F_r$

The values of e , Y_1 , and Y_0 are given in the table below.

Boundary Dimensions (mm)							Basic Load Ratings				Limiting Speeds	
<i>d</i>	<i>D</i>	<i>T</i>	<i>B</i>	<i>C</i>	Cone <i>r</i>	Cup <i>r</i>	(N)		(kgf)		Grease	Oil
							<i>C_r</i>	<i>C_{0r}</i>	<i>C_r</i>	<i>C_{0r}</i>	(min ⁻¹)	
15	35	11.75	11	10	0.6	0.6	14 800	13 200	1 510	1 350	11 000	15 000
	42	14.25	13	11	1	1	23 600	21 100	2 400	2 160	9 500	13 000
17	40	13.25	12	11	1	1	20 100	19 900	2 050	2 030	9 500	13 000
	40	17.25	16	14	1	1	27 100	28 000	2 770	2 860	9 500	13 000
	47	15.25	14	12	1	1	29 200	26 700	2 980	2 720	8 500	12 000
	47	15.25	14	10.5	1	1	22 000	20 300	2 240	2 070	8 000	11 000
	47	20.25	19	16	1	1	37 500	36 500	3 800	3 750	8 500	11 000
20	42	15	15	12	0.6	0.6	24 600	27 400	2 510	2 800	9 000	12 000
	47	15.25	14	12	1	1	27 900	28 500	2 850	2 900	8 000	11 000
	47	15.25	14	12	0.3	1	23 900	24 000	2 430	2 450	8 000	11 000
	47	19.25	18	15	1	1	35 500	37 500	3 650	3 850	8 500	11 000
	47	19.25	18	15	1	1	31 500	33 500	3 200	3 400	8 000	11 000
	52	16.25	15	13	1.5	1.5	35 000	33 500	3 550	3 400	7 500	10 000
	52	16.25	15	12	1.5	1.5	25 300	24 500	2 580	2 490	7 100	10 000
	52	22.25	21	18	1.5	1.5	45 500	47 500	4 650	4 850	8 000	11 000
22	44	15	15	11.5	0.6	0.6	25 600	29 400	2 610	3 000	8 500	11 000
	50	15.25	14	12	1	1	29 200	30 500	2 980	3 150	7 500	10 000
	50	15.25	14	12	1	1	27 200	29 500	2 780	3 000	7 500	10 000
	50	19.25	18	15	1	1	36 500	40 500	3 750	4 100	7 500	11 000
	50	19.25	18	15	1	1	33 500	39 500	3 400	4 000	7 500	10 000
	56	17.25	16	14	1.5	1.5	37 000	36 500	3 750	3 750	7 100	9 500
	56	17.25	16	13	1.5	1.5	34 500	34 000	3 500	3 500	6 700	9 500
25	47	15	15	11.5	0.6	0.6	27 400	33 000	2 800	3 400	8 000	11 000
	47	17	17	14	0.6	0.6	31 000	38 000	3 150	3 900	8 000	11 000
	52	16.25	15	13	1	1	32 000	35 000	3 300	3 550	7 100	10 000
	52	16.25	15	12	1	1	28 100	31 500	2 860	3 200	9 700	9 500
	52	19.25	18	16	1	1	40 000	45 000	4 050	4 600	7 100	10 000
	52	19.25	18	15	1	1	35 000	42 000	3 550	4 250	7 100	9 500
	52	22	22	18	1	1	47 500	56 500	4 850	5 750	7 500	10 000
	62	18.25	17	15	1.5	1.5	47 500	46 000	4 850	4 700	6 300	8 500
	62	18.25	17	14	1.5	1.5	42 000	45 000	4 300	4 550	6 000	8 500
	62	18.25	17	13	1.5	1.5	38 000	40 500	3 900	4 100	5 600	8 000
	62	18.25	17	13	1.5	1.5	38 000	40 500	3 900	4 100	5 600	8 000
	62	25.25	24	20	1.5	1.5	62 500	66 000	6 400	6 750	6 300	8 500
28	52	16	16	12	1	1	32 000	39 000	3 300	3 950	7 100	9 500
	58	17.25	16	14	1	1	39 500	41 500	4 050	4 200	6 300	9 000
	58	17.25	16	12	1	1	34 000	38 500	3 450	3 900	6 300	8 500
	58	20.25	19	16	1	1	47 500	54 000	4 850	5 500	6 300	9 000
	58	20.25	19	16	1	1	42 000	49 500	4 300	5 050	6 300	9 000
	68	19.75	18	15	1.5	1.5	55 000	55 500	5 650	5 650	6 000	8 000
	68	19.75	18	14	1.5	1.5	49 500	50 500	5 000	5 150	5 600	7 500

Bearing Numbers	ISO355 Dimension Series approx.	Abutment and Fillet Dimensions (mm)								Eff. Load Centers (mm) <i>a</i>	Constant <i>e</i>	Axial Load Factors		Mass (kg) approx.	
		<i>d_a</i> min.	<i>d_b</i> max.	<i>D_a</i> max.	<i>D_b</i> min.	<i>S_a</i> min.	<i>S_b</i> min.	Cone <i>r_a</i> max.	Cup <i>r_a</i> max.			<i>Y₁</i>	<i>Y₀</i>		
30202	—	23	19	30	30	33	2	1.5	0.6	0.6	8.2	0.32	1.9	1.0	0.053
HR 30302 J	2FB	24	22	36	36	38.5	2	3	1	1	9.5	0.29	2.1	1.2	0.098
HR 32203 J	2DB	26	23	34	34	37.5	2	2	1	1	9.7	0.35	1.7	0.96	0.079
HR 32203 J	2DD	26	22	34	34	37	2	3	1	1	11.2	0.31	1.9	1.1	0.103
HR 30303 J	2FB	26	24	41	40	43	2	3	1	1	10.4	0.29	2.1	1.2	0.134
30303 D	—	29	23	41	34	44	2	4.5	1	1	15.4	0.81	0.74	0.41	0.129
HR 32303 J	2FD	28	23	41	39	43	2	4	1	1	12.5	0.29	2.1	1.2	0.178
HR 32004 XJ	3CC	28	24	37	35	40	3	3	0.6	0.6	10.6	0.37	1.6	0.88	0.097
HR 32024 J	2DB	29	27	41	40	44	2	3	1	1	11.0	0.35	1.7	0.96	0.127
HR 32024 C-A-	—	29	26	41	37	44	2	3	0.3	1	13.0	0.55	1.1	0.60	0.126
HR 32204 J	2DD	29	25	41	38	44.5	3	4	1	1	12.6	0.33	1.8	1.0	0.161
HR 32204 CJ	5DD	29	25	41	36	44	2	4	1	1	14.5	0.52	1.2	0.64	0.166
HR 30304 J	2FB	31	27	44	44	47.5	2	3	1.5	1.5	11.6	0.30	2.0	1.1	0.172
30304 D	—	34	26	43	37	49	2	4	1.5	1.5	16.7	0.81	0.74	0.41	0.168
HR 32304 J	2FD	33	26	43	42	48	3	4	1.5	1.5	13.9	0.30	2.0	1.1	0.241
HR 320/22 XJ	3CC	30	27	39	37	42	3	3.5	0.6	0.6	11.1	0.40	1.5	0.83	0.103
HR 302/22	—	31	29	44	42	47	2	3	1	1	11.6	0.37	1.6	0.90	0.139
HR 302/22 C	—	31	29	44	40	47	2	3	1	1	13.0	0.49	1.2	0.67	0.144
HR 322/22	—	31	28	44	41	47	2	4	1	1	13.5	0.37	1.6	0.89	0.18
HR 322/22 C	—	31	29	44	39	48	2	4	1	1	15.2	0.51	1.2	0.65	0.185
HR 303/22	—	33	30	47	46	50	2	3	1.5	1.5	12.4	0.32	1.9	1.0	0.208
HR 303/22 C	—	33	30	47	44	52.5	3	4	1.5	1.5	15.9	0.59	1.0	0.56	0.207
HR 32005 XJ	4CC	33	30	42	40	45	3	3.5	0.6	0.6	11.8	0.43	1.4	0.77	0.116
HR 33005 J	2CE	33	29	42	41	44	3	3	0.6	0.6	11.0	0.29	2.1	1.1	0.131
HR 30205 J	3CC	34	31	46	44	48.5	2	3	1	1	12.7	0.37	1.6	0.88	0.157
HR 30205 C	—	34	32	46	43	49.5	2	4	1	1	14.4	0.53	1.1	0.62	0.155
HR 32205 J	2CD	34	30	46	44	50	2	3	1	1	13.5	0.36	1.7	0.92	0.189
HR 32205 C	—	34	30	46	40	50	2	4	1	1	15.8	0.53	1.1	0.62	0.19
HR 33205 J	2DE	34	29	46	43	49.5	4	4	1	1	14.1	0.35	1.7	0.94	0.221
HR 30305 J	2FB	36	34	54	54	57	2	3	1.5	1.5	13.2	0.30	2.0	1.1	0.27
HR 30305 C	—	36	35	53	49	58.5	3	4	1.5	1.5	16.4	0.55	1.1	0.60	0.276
HR 30305 DJ	(7FB)	39	34	53	47	59	2	5	1.5	1.5	19.9	0.83	0.73	0.40	0.265
HR 31305 J	7FB	39	33	53	47	59	3	5	1.5	1.5	19.9	0.83	0.73	0.40	0.265
HR 32305 J	2FD	38	32	53	51	57	3	5	1.5	1.5	15.6	0.30	2.0	1.1	0.376
HR 320/28 XJ	4CC	37	33	46	44	50	3	4	1	1	12.8	0.43	1.4	0.77	0.146
HR 302/28	—	37	34	52	50	55	2	3	1	1	13.2	0.35	1.7	0.93	0.203
HR 302/28 C	—	37	34	52	48	54	2	5	1	1	16.9	0.64	0.94	0.52	0.198
HR 322/28	—	37	34	52	49	55	2	4	1	1	14.6	0.37	1.6	0.89	0.243
HR 322/28 CJ	5DD	37	33	52	45	55	2	4	1	1	16.8	0.56	1.1	0.59	0.251
HR 303/28	—	39	37	59	58	61	2	4.5	1.5	1.5	14.5	0.31	1.9	1.1	0.341
HR 303/28 C	—	39	38	59	57	63	3	5.5	1.5	1.5	17.4	0.52	1.2	0.64	0.335

Remarks The suffix C represents medium-angle tapered roller bearings. Since they are designed for specific applications, please consult NSK when using bearings with suffix C.

Bore Diameter 30 – 35 mm

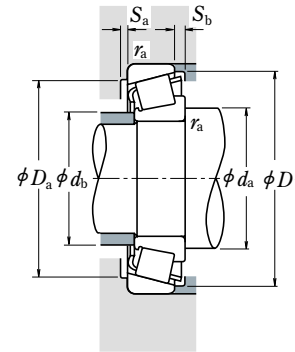
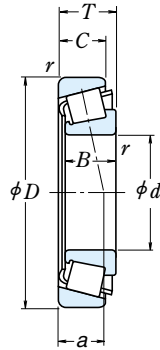

Dynamic Equivalent Load

$$P = XF_r + YF_a$$

$F_a/F_r \leq e$		$F_a/F_r > e$	
X	Y	X	Y
1	0	0.4	Y_1

Static Equivalent Load

$$P_0 = 0.5F_r + Y_0F_a$$

When $F_r > 0.5F_r + Y_0F_a$, use $P_0 = F_r$

The values of e , Y_1 , and Y_0 are given in the table below.

d	Boundary Dimensions (mm)				Cone		Basic Load Ratings				Limiting Speeds		
	D	T	B	C	r	Cup min.	C_r (N)	C_{0r} (kgf)	C_r (kgf)	C_{0r} (kgf)	Grease	Oil	
30	47	12	12	9	0.3	0.3	17 600	24 400	1 800	2 490	7 500	10 000	
	55	17	17	13	1	1	36 000	44 500	3 700	4 550	6 700	9 000	
	55	20	20	16	1	1	42 000	54 000	4 250	5 500	6 700	9 000	
	62	17.25	16	14	1	1	43 000	47 500	4 400	4 850	6 000	8 000	
	62	17.25	16	12	1	1	35 500	37 000	3 650	3 800	5 600	7 500	
	62	21.25	20	17	1	1	52 000	60 000	5 300	6 150	6 000	8 500	
	62	21.25	20	16	1	1	48 000	56 000	4 900	5 750	6 000	8 000	
	62	25	25	19.5	1	1	66 500	79 500	6 800	8 100	6 000	8 000	
	72	20.75	19	16	1.5	1.5	59 500	60 000	6 050	6 100	5 300	7 500	
	72	20.75	19	14	1.5	1.5	56 500	55 500	5 800	5 650	5 300	7 100	
	72	20.75	19	14	1.5	1.5	49 000	52 500	5 000	5 350	4 800	6 700	
	72	20.75	19	14	1.5	1.5	49 000	52 500	5 000	5 350	4 800	6 800	
72	28.75	27	23	1.5	1.5	80 000	88 500	8 150	9 000	5 600	7 500		
72	28.75	27	23	1.5	1.5	76 000	86 500	7 750	8 800	5 600	7 500		
32	58	17	17	13	1	1	37 500	47 000	3 800	4 800	6 300	8 500	
	58	21	20	16	1	1	41 000	50 000	4 150	5 100	6 300	8 500	
	65	18.25	17	15	1	1	48 500	54 000	4 950	5 500	5 600	8 000	
	65	18.25	17	14	1	1	45 500	52 500	4 650	5 350	5 600	7 500	
	65	22.25	21	18	1	1	56 000	65 000	5 700	6 650	6 000	8 000	
	65	22.25	21	17	1	1	49 500	60 000	5 050	6 100	5 600	7 500	
	65	26	26	20.5	1	1	70 000	86 500	7 150	8 850	5 600	8 000	
	75	21.75	20	17	1.5	1.5	56 000	56 000	5 700	5 700	5 300	7 100	
	35	55	14	14	11.5	0.6	0.6	27 400	39 000	2 790	3 950	6 300	8 500
		62	18	18	14	1	1	43 500	55 500	4 400	5 650	5 600	8 000
		62	21	21	17	1	1	49 000	65 000	4 950	6 650	5 600	8 000
		72	18.25	17	15	1.5	1.5	54 000	59 500	5 500	6 050	5 300	7 100
72		18.25	17	13	1.5	1.5	47 000	54 500	4 750	5 550	5 000	6 700	
72		24.25	23	19	1.5	1.5	70 500	83 500	7 150	8 550	5 300	7 100	
72		24.25	23	18	1.5	1.5	60 500	71 500	6 200	7 300	5 000	7 100	
72		28	28	22	1.5	1.5	86 500	108 000	8 850	11 100	5 300	7 100	
80		22.75	21	18	2	1.5	76 000	79 000	7 750	8 050	4 800	6 700	
80		22.75	21	16	2	1.5	68 000	70 500	6 900	7 200	4 800	6 300	
80		22.75	21	15	2	1.5	62 000	68 000	6 350	6 950	4 300	6 000	
80		22.75	21	15	2	1.5	62 000	68 000	6 350	6 950	4 300	6 000	
80	32.75	31	25	2	1.5	99 000	111 000	10 100	11 300	5 000	6 700		

Remarks The suffix C represents medium-angle tapered roller bearings. Since they are designed for specific applications, please consult NSK when using bearings with suffix C.

Bearing Numbers	ISO355 Dimension Series approx.	Abutment and Fillet Dimensions (mm)								Eff. Load Centers (mm) a	Constant e	Axial Load Factors		Mass (kg) approx.	
		d_a min.	d_b max.	D_a max.	D_b min.	S_a min.	S_b min.	Cone max.	Cup max.			Y_1	Y_0		
HR 32906 J HR 32006 XJ HR 33006 J	2BD	34	34	44	42	44	3	3	0.3	0.3	9.2	0.32	1.9	1.0	0.074
	4CC	39	35	49	47	53	3	4	1	1	13.5	0.43	1.4	0.77	0.172
	2CE	39	35	49	48	52	3	4	1	1	13.1	0.29	2.1	1.1	0.208
HR 30206 J HR 30206 C HR 32206 J	3DB	39	37	56	52	58	2	3	1	1	13.9	0.37	1.6	0.88	0.238
	—	39	36	56	49	59	2	5	1	1	17.8	0.68	0.88	0.49	0.221
	3DC	39	36	56	51	58.5	2	4	1	1	15.4	0.37	1.6	0.88	0.297
HR 32206 C HR 32206 J HR 30306 J HR 30306 C	—	39	35	56	48	59	2	5	1	1	17.8	0.55	1.1	0.60	0.293
	2DE	39	35	56	52	59.5	5	5.5	1	1	16.1	0.34	1.8	0.97	0.355
	2FB	41	40	63	62	66	3	4.5	1.5	1.5	15.1	0.32	1.9	1.1	0.403
HR 30306 DJ HR 32306 J HR 32306 CJ	—	41	38	63	59	67	3	6.5	1.5	1.5	18.5	0.55	1.1	0.60	0.383
	(7FB)	44	40	63	55	68	3	6.5	1.5	1.5	23.1	0.83	0.73	0.40	0.393
	7FB	44	40	63	55	68	3	6.5	1.5	1.5	23.1	0.83	0.73	0.40	0.393
HR 32306 J HR 32306 CJ	2FD	43	38	63	59	66	3	5.5	1.5	1.5	18.0	0.32	1.9	1.1	0.57
	5FD	43	36	63	54	68	3	5.5	1.5	1.5	22.0	0.55	1.1	0.60	0.583
	—	43	36	63	54	68	3	5.5	1.5	1.5	22.0	0.55	1.1	0.60	0.583
HR 320/32 XJ 330/32	4CC	41	37	52	49	55	3	4	1	1	14.2	0.45	1.3	0.73	0.191
	—	41	37	52	50	55	2	4	1	1	13.8	0.31	1.9	1.1	0.225
	—	41	39	59	56	61	3	3	1	1	14.7	0.37	1.6	0.88	0.277
HR 302/32 HR 302/32 C	—	41	39	59	54	62	3	4	1	1	16.9	0.55	1.1	0.60	0.273
	—	41	38	59	54	61	3	4	1	1	15.9	0.37	1.6	0.88	0.336
	—	41	39	59	51	62	3	5	1	1	20.2	0.59	1.0	0.56	0.335
HR 332/32 J 303/32	2DE	41	38	59	55	62	5	5.5	1	1	17.0	0.35	1.7	0.95	0.40
	—	44	42	66	64	68	3	4.5	1.5	1.5	15.9	0.33	1.8	1.0	0.435
	—	44	42	66	64	68	3	4.5	1.5	1.5	15.9	0.33	1.8	1.0	0.435
HR 32907 J HR 32007 XJ HR 33007 J	2BD	43	40	50	50	52.5	3	2.5	0.6	0.6	10.7	0.29	2.1	1.1	0.123
	4CC	44	40	56	54	60	4	4	1	1	15.0	0.45	1.3	0.73	0.229
	2CE	44	40	56	55	59	4	4	1	1	14.1	0.31	2.0	1.1	0.267
HR 30207 J HR 30207 C HR 32207 J	3DB	46	43	63	62	67	3	3	1.5	1.5	15.0	0.37	1.6	0.88	0.34
	—	46	44	63	59	68	3	5	1.5	1.5	19.6	0.66	0.91	0.50	0.331
	3DC	46	42	63	61	67.5	3	5	1.5	1.5	17.9	0.37	1.6	0.88	0.456
HR 32207 C HR 33207 J HR 30307 J	—	46	42	63	58	68.5	3	6	1.5	1.5	20.6	0.55	1.1	0.60	0.442
	2DE	46	41	63	61	68	5	6	1.5	1.5	18.3	0.35	1.7	0.93	0.54
	2FB	47	45	71	69	74	3	4.5	2	1.5	16.7	0.32	1.9	1.1	0.538
HR 30307 C HR 30307 DJ HR 31307 J HR 32307 J	—	47	44	71	65	74	3	6.5	2	1.5	20.3	0.55	1.1	0.60	0.518
	7FB	51	44	71	62	77	3	7.5	2	1.5	25.2	0.83	0.73	0.40	0.519
	7FB	51	44	71	62	77	3	7.5	2	1.5	25.2	0.83	0.73	0.40	0.52
	2FE	49	43	71	66	74	3	7.5	2	1.5	20.7	0.32	1.9	1.1	0.765

Bore Diameter 40 – 50 mm

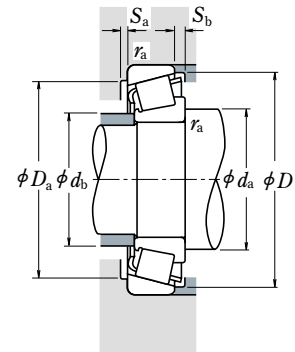
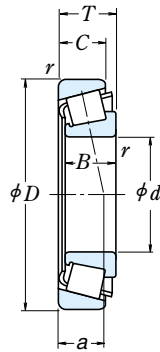

Dynamic Equivalent Load

$$P = X F_r + Y F_a$$

$F_a/F_r \leq e$		$F_a/F_r > e$	
X	Y	X	Y
1	0	0.4	Y_1

Static Equivalent Load

$$P_0 = 0.5 F_r + Y_0 F_a$$

When $F_r > 0.5 F_r + Y_0 F_a$, use $P_0 = F_r$

The values of e , Y_1 , and Y_0 are given in the table below.

d	Boundary Dimensions (mm)				Cone		Basic Load Ratings				Limiting Speeds	
	D	T	B	C	r	Cup min.	C_r	C_{0r}	C_r	C_{0r}	Grease	Oil
40	62	15	15	12	0.6	0.6	34 000	47 000	3 450	4 800	5 600	7 500
	68	19	19	14.5	1	1	53 000	71 000	5 400	7 250	5 300	7 100
	68	22	22	18	1	1	59 000	81 500	6 000	8 300	5 300	7 100
	75	26	26	20.5	1.5	1.5	78 500	101 000	8 000	10 300	4 800	6 700
	80	19.75	18	16	1.5	1.5	63 500	70 000	6 450	7 150	4 800	6 300
	80	24.75	23	19	1.5	1.5	77 000	90 500	7 900	9 200	4 800	6 300
	80	24.75	23	19	1.5	1.5	74 000	90 500	7 550	9 200	4 500	6 300
	80	32	32	25	1.5	1.5	107 000	137 000	10 900	14 000	4 800	6 300
	90	25.25	23	20	2	1.5	90 500	101 000	9 250	10 300	4 300	5 600
	90	25.25	23	18	2	1.5	84 500	93 500	8 600	9 500	4 300	5 600
	90	25.25	23	17	2	1.5	80 000	89 500	8 150	9 150	3 800	5 300
	90	25.25	23	17	2	1.5	80 000	89 500	8 150	9 150	3 800	5 300
90	35.25	33	27	2	1.5	120 000	145 000	12 200	14 800	4 300	6 000	
45	68	15	15	12	0.6	0.6	34 500	50 500	3 550	5 150	5 000	6 700
	75	20	20	15.5	1	1	60 000	83 000	6 150	8 450	4 500	6 300
	75	24	24	19	1	1	69 000	99 000	7 050	10 100	4 800	6 300
	80	26	26	20.5	1.5	1.5	84 000	113 000	8 550	11 600	4 500	6 000
	85	20.75	19	16	1.5	1.5	68 500	79 500	6 950	8 100	4 300	6 000
	85	24.75	23	19	1.5	1.5	83 000	102 000	8 500	10 400	4 300	6 000
	85	24.75	23	19	1.5	1.5	75 500	95 500	7 700	9 750	4 300	5 600
	85	32	32	25	1.5	1.5	111 000	147 000	11 300	15 000	4 300	6 000
	95	29	26.5	20	2.5	2.5	88 500	109 000	9 050	11 100	3 600	5 000
	95	36	35	30	2.5	2.5	139 000	174 000	14 200	17 800	4 000	5 300
	100	27.25	25	22	2	1.5	112 000	127 000	11 400	12 900	3 800	5 300
	100	27.25	25	18	2	1.5	95 500	109 000	9 750	11 100	3 400	4 800
100	27.25	25	18	2	1.5	95 500	109 000	9 750	11 100	3 400	4 800	
100	38.25	36	30	2	1.5	144 000	177 000	14 700	18 000	3 800	5 300	
50	100	36	35	30	2.5	2.5	144 000	185 000	14 600	18 800	3 800	5 000
	72	15	15	12	0.6	0.6	36 000	54 000	3 650	5 500	4 500	6 300
	80	20	20	15.5	1	1	61 000	87 000	6 250	8 900	4 300	6 000
	80	24	24	19	1	1	70 500	104 000	7 150	10 600	4 300	6 000
	85	26	26	20	1.5	1.5	89 000	126 000	9 100	12 800	4 300	5 600
	90	21.75	20	17	1.5	1.5	76 000	91 500	7 750	9 300	4 000	5 300
	90	24.75	23	19	1.5	1.5	87 500	109 000	8 900	11 100	4 000	5 300
	90	24.75	23	18	1.5	1.5	77 500	102 000	7 900	10 400	3 800	5 300
	90	32	32	24.5	1.5	1.5	118 000	165 000	12 100	16 800	4 000	5 300
	105	32	29	22	3	3	109 000	133 000	11 100	13 600	3 200	4 500
	110	29.25	27	23	2.5	2	130 000	148 000	13 300	15 100	3 400	4 800
	110	29.25	27	19	2.5	2	114 000	132 000	11 700	13 400	3 200	4 300
110	29.25	27	19	2.5	2	114 000	132 000	11 700	13 400	3 200	4 300	
110	42.25	40	33	2.5	2	176 000	220 000	17 900	22 400	3 600	4 800	
110	42.25	40	33	2.5	2	164 000	218 000	16 800	22 200	3 400	4 800	

Bearing Numbers	ISO355 Dimension Series approx.	Abutment and Fillet Dimensions (mm)						Cone Cup	Eff. Load Centers (mm) a	Constant e	Axial Load Factors		Mass (kg) approx.		
		d_a min.	d_b max.	D_a max.	D_b min.	S_a min.	S_b min.				Y_1	Y_0			
HR 32908 J	2BC	48	44	57	57	59	3	3	0.6	0.6	11.5	0.29	2.1	1.1	0.161
HR 32008 XJ	3CD	49	45	62	60	65.5	4	4.5	1	1	15.0	0.38	1.6	0.87	0.28
HR 33008 J	2BE	49	45	62	61	65	4	4	1	1	14.6	0.28	2.1	1.2	0.322
HR 33108 J	2CE	51	46	66	65	71	4	5.5	1.5	1.5	18.0	0.36	1.7	0.93	0.503
HR 30208 J	3DB	51	48	71	69	75	3	3.5	1.5	1.5	16.6	0.37	1.6	0.88	0.437
HR 32208 J	3DC	51	48	71	68	75	3	5.5	1.5	1.5	18.9	0.37	1.6	0.88	0.548
HR 32208 CJ	5DC	51	47	71	65	76	3	5.5	1.5	1.5	21.9	0.55	1.1	0.60	0.558
HR 33208 J	2DE	51	46	71	67	76	5	7	1.5	1.5	20.8	0.36	1.7	0.92	0.744
HR 30308 J	2FB	52	52	81	76	82	3	5	2	1.5	19.5	0.35	1.7	0.96	0.758
HR 30308 C	—	52	50	81	72	84	3	7	2	1.5	22.8	0.53	1.1	0.62	0.735
HR 30308 DJ	7FB	56	50	81	70	87	3	8	2	1.5	28.7	0.83	0.73	0.40	0.728
HR 31308 J	7FB	56	50	81	70	87	3	8	2	1.5	28.7	0.83	0.73	0.40	0.728
HR 32308 J	2FD	54	50	81	73	82	3	8	2	1.5	23.4	0.35	1.7	0.96	1.05
HR 32909 J	2BC	53	50	63	62	64	3	3	0.6	0.6	12.3	0.32	1.9	1.0	0.187
HR 32009 XJ	3CC	54	51	69	67	72	4	4.5	1	1	16.6	0.39	1.5	0.84	0.354
HR 33009 J	2CE	54	51	69	67	71	4	5	1	1	16.3	0.29	2.0	1.1	0.414
HR 33109 J	3CE	56	51	71	69	77	4	5.5	1.5	1.5	19.1	0.38	1.6	0.86	0.552
HR 30209 J	3DB	56	53	76	74	80	3	4.5	1.5	1.5	18.3	0.41	1.5	0.81	0.488
HR 32209 J	3DC	56	53	76	73	81	3	5.5	1.5	1.5	20.1	0.41	1.5	0.81	0.602
HR 32209 CJ	5DC	56	52	76	70	82	3	5.5	1.5	1.5	23.6	0.59	1.0	0.56	0.603
HR 33209 J	3DE	56	51	76	72	81	5	7	1.5	1.5	22.0	0.39	1.6	0.86	0.817
T 7 FC045	7FC	60	53	83	71	91	3	9	2	2	32.1	0.87	0.69	0.38	0.918
T 2 ED045	2ED	60	54	83	79	89	5	6	2	2	23.5	0.32	1.9	1.02	1.22
HR 30309 J	2FB	57	58	91	86	93	3	5	2	1.5	21.1	0.35	1.7	0.96	1.01
HR 30309 DJ	7FB	61	57	91	79	96	3	9	2	1.5	31.5	0.83	0.73	0.40	0.957
HR 31309 J	7FB	61	57	91	79	96	3	9	2	1.5	31.5	0.83	0.73	0.40	0.947
HR 32309 J	2FD	59	56	91	82	93	3	8	2	1.5	25.0	0.35	1.7	0.96	1.42
T 2 ED050	2ED	65	59	88	83	94	6	6	2	2	24.2	0.34	1.8	0.96	1.3
HR 32910 J	2BC	58	54	67	66	69	3	3	0.6	0.6	13.5	0.34	1.8	0.97	0.193
HR 32010 XJ	3CC	59	56	74	71	77	4	4.5	1	1	17.9	0.42	1.4	0.78	0.38
HR 33010 J	2CE	59	55	74	71	76	4	5	1	1	17.4	0.32	1.9	1.0	0.452
HR 33110 J	3CE	61	56	76	74	82	4	6	1.5	1.5	20.3	0.41	1.5	0.8	0.597
HR 30210 J	3DB	61	58	81	79	85	3	4.5	1.5	1.5	19.6	0.42	1.4	0.79	0.557
HR 32210 J	3DC	61	57	81	78	86	3	5.5	1.5	1.5	21.0	0.42	1.4	0.79	0.642
HR 32210 CJ	5DC	61	58	81	76	87	3	6.5	1.5	1.5	24.6	0.59	1.0	0.56	0.655
HR 33210 J	3DE	61	56	81	76	87	5	7.5	1.5	1.5	23.2	0.41	1.5	0.80	0.867
T 7 FC050	7FC	74	59	91	78	100	5	10	2.5	2.5	36.4	0.87	0.69	0.38	1.22
HR 30310 J	2FB	65	65	100	95	102	3	6	2	2	23.1	0.35	1.7	0.96	1.2

Bore Diameter 55 – 65 mm

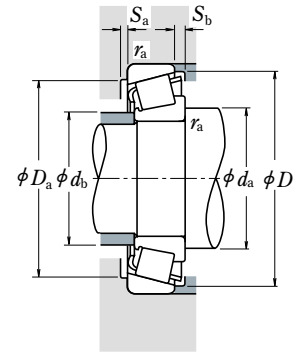
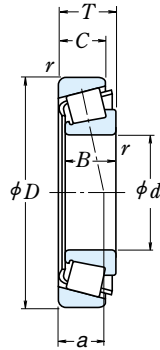

Dynamic Equivalent Load

$$P = X F_r + Y F_a$$

$F_a/F_r \leq e$		$F_a/F_r > e$	
X	Y	X	Y
1	0	0.4	Y_1

Static Equivalent Load

$$P_0 = 0.5 F_r + Y_0 F_a$$

When $F_r > 0.5 F_r + Y_0 F_a$, use $P_0 = F_r$

The values of e , Y_1 , and Y_0 are given in the table below.

Boundary Dimensions (mm)						Basic Load Ratings				Limiting Speeds	
d	D	T	B	C	Cone Cup	(N)		{kgf}		(min ⁻¹)	
					r min.	C_r	C_{0r}	C_r	C_{0r}	Grease	Oil
55	80	17	17	14	1	45 500	74 500	4 600	7 600	4 300	5 600
	90	23	23	17.5	1.5	81 500	117 000	8 300	11 900	3 800	5 300
	90	27	27	21	1.5	91 500	138 000	9 300	14 000	3 800	5 300
	95	30	30	23	1.5	112 000	158 000	11 500	16 100	3 800	5 000
	100	22.75	21	18	2	94 500	113 000	9 650	11 500	3 600	5 000
	100	26.75	25	21	2	110 000	137 000	11 200	14 000	3 600	5 000
	100	35	35	27	2	141 000	193 000	14 400	19 700	3 600	5 000
	115	34	31	23.5	3	126 000	164 000	12 800	16 700	3 000	4 300
	120	31.5	29	25	2.5	150 000	171 000	15 200	17 500	3 200	4 300
	120	31.5	29	21	2.5	131 000	153 000	13 400	15 600	2 800	4 000
	120	31.5	29	21	2.5	131 000	153 000	13 400	15 600	2 800	4 000
	120	45.5	43	35	2.5	204 000	258 000	20 800	26 300	3 200	4 300
120	45.5	43	35	2.5	195 000	262 000	19 900	26 700	3 200	4 300	
60	85	17	17	14	1	49 000	84 500	5 000	8 650	3 800	5 300
	95	23	23	17.5	1.5	85 500	127 000	8 700	12 900	3 600	5 000
	95	27	27	21	1.5	96 000	150 000	9 800	15 300	3 600	5 000
	100	30	30	23	1.5	115 000	166 000	11 700	16 900	3 400	4 800
	110	23.75	22	19	2	104 000	123 000	10 600	12 500	3 400	4 500
	110	29.75	28	24	2	131 000	167 000	13 400	17 000	3 400	4 500
	110	38	38	29	2	166 000	231 000	16 900	23 600	3 400	4 500
	125	37	33.5	26	3	151 000	197 000	15 400	20 100	2 800	3 800
	130	33.5	31	26	3	174 000	201 000	17 700	20 500	3 000	4 000
	130	33.5	31	22	3	151 000	177 000	15 400	18 100	2 600	3 800
	130	33.5	31	22	3	151 000	177 000	15 400	18 100	2 600	3 800
	130	48.5	46	37	3	233 000	295 000	23 700	30 000	3 000	4 000
130	48.5	46	35	3	196 000	249 000	20 000	25 400	2 800	3 800	
65	90	17	17	14	1	49 000	86 500	5 000	8 800	3 600	5 000
	100	23	23	17.5	1.5	86 500	132 000	8 800	13 500	3 400	4 500
	100	27	27	21	1.5	97 500	156 000	9 950	15 900	3 400	4 500
	110	34	34	26.5	1.5	148 000	218 000	15 100	22 200	3 200	4 300
	120	24.75	23	20	2	122 000	151 000	12 500	15 400	3 000	4 000
	120	32.75	31	27	2	157 000	202 000	16 000	20 600	3 000	4 000
	120	41	41	32	2	202 000	282 000	20 600	28 800	3 000	4 000
	140	36	33	28	3	200 000	233 000	20 400	23 800	2 600	3 600
	140	36	33	23	3	173 000	205 000	17 700	20 900	2 400	3 400
	140	36	33	23	3	173 000	205 000	17 700	20 900	2 400	3 400
	140	51	48	39	3	267 000	340 000	27 300	35 000	2 800	3 800

Remarks The suffix C represents medium-angle tapered roller bearings. Since they are designed for specific applications, please consult NSK when using bearings with suffix C.

Bearing Numbers	ISO355 Dimension Series approx.	Abutment and Fillet Dimensions (mm)						Cone Cup	Eff. Load Centers (mm) a	Constant e	Axial Load Factors		Mass (kg) approx.		
		d_a min.	d_b max.	D_a max.	D_b min.	S_a min.	S_b min.				Y_1	Y_0			
HR 32911 J	2BC	64	60	74	73	76	4	3	1	1	14.6	0.31	1.9	1.1	0.282
HR 32011 XJ	3CC	66	62	81	80	86	4	5.5	1.5	1.5	19.7	0.41	1.5	0.81	0.568
HR 33011 J	2CE	66	62	81	80	86	5	6	1.5	1.5	19.2	0.31	1.9	1.1	0.657
HR 33111 J	3CE	66	62	86	82	91	5	7	1.5	1.5	22.4	0.37	1.6	0.88	0.877
HR 30211 J	3DB	67	64	91	89	94	4	4.5	2	1.5	20.9	0.41	1.5	0.81	0.736
HR 32211 J	3DC	67	63	91	87	95	4	5.5	2	1.5	22.7	0.41	1.5	0.81	0.859
HR 33211 J	3DE	67	62	91	86	96	6	8	2	1.5	25.2	0.40	1.5	0.83	1.18
T 7 FC055	7FC	73	66	101	86	109	4	10.5	2.5	2.5	39.0	0.87	0.69	0.38	1.58
HR 30311 J	2FB	70	71	110	104	111	4	6.5	2	2	24.6	0.35	1.7	0.96	1.63
HR 30311 DJ	7FB	75	67	110	94	114	4	10.5	2	2	37.0	0.83	0.73	0.40	1.58
HR 31311 J	7FB	75	67	110	94	114	4	10.5	2	2	37.0	0.83	0.73	0.40	1.58
HR 32311 J	2FD	73	67	110	99	111	4	10.5	2	2	29.9	0.35	1.7	0.96	2.39
HR 32311 CJ	5FD	73	65	110	91	112	4	10.5	2	2	35.8	0.55	1.1	0.60	2.47
HR 32912 J	2BC	69	65	79	78	81	4	3	1	1	15.5	0.33	1.8	1.0	0.306
HR 32012 XJ	4CC	71	66	86	85	91	4	5.5	1.5	1.5	20.9	0.43	1.4	0.77	0.608
HR 33012 J	2CE	71	66	86	85	90	5	6	1.5	1.5	20.0	0.33	1.8	1.0	0.713
HR 33112 J	3CE	71	68	91	88	96	5	7	1.5	1.5	23.6	0.40	1.5	0.83	0.91
HR 30212 J	3EB	72	69	101	96	103	4	4.5	2	1.5	22.0	0.41	1.5	0.81	0.930
HR 32212 J	3EC	72	68	101	95	104	4	5.5	2	1.5	24.1	0.41	1.5	0.81	1.18
HR 33212 J	3EE	72	68	101	94	105	6	9	2	1.5	27.6	0.40	1.5	0.82	1.56
T 7 FC060	7FC	78	72	111	94	119	4	11	2.5	2.5	41.4	0.82	0.73	0.40	2.03
HR 30312 J	2FB	78	77	118	112	120	4	7.5	2.5	2	26.0	0.35	1.7	0.96	2.03
HR 30312 DJ	7FB	84	74	118	103	125	4	11.5	2.5	2	40.3	0.83	0.73	0.40	1.98
HR 31312 J	7FB	84	74	118	103	125	4	11.5	2.5	2	40.3	0.83	0.73	0.40	1.98
HR 32312 J	2FD	81	74	118	107	120	4	11.5	2.5	2	31.4	0.35	1.7	0.96	2.96
32312 C	—	81	74	116	102	125	4	13.5	2.5	2	39.9	0.58	1.0	0.57	2.86
HR 32913 J	2BC	74	70	84	82	86	4	3	1	1	16.8	0.35	1.7	0.93	0.323
HR 32013 XJ	4CC	76	71	91	90	97	4	5.5	1.5	1.5	22.4	0.46	1.3	0.72	0.646
HR 33013 J	2CE	76	71	91	90	96	5	6	1.5	1.5	21.1	0.35	1.7	0.95	0.76
HR 33113 J	3DE	76	73	101	96	106	6	7.5	1.5	1.5	26.0	0.39	1.5	0.85	1.32
HR 30213 J	3EB	77	78	111	106	113	4	4.5	2	1.5	23.8	0.41	1.5	0.81	1.18
HR 32213 J	3EC	77	75	111	104	115	4	5.5	2	1.5	27.1	0.41	1.5	0.81	1.55
HR 33213 J	3EE	77	74	111	102	115	6	9	2	1.5	29.2	0.39	1.5	0.85	2.04
HR 30313 J	2GB	83	83	128	121	130	4	8	2.5	2	27.9	0.35	1.7	0.96	2.51
HR 30313 DJ	7GB	89	80	128	111	133	4	13	2.5	2	43.2	0.83	0.73	0.40	2.43
HR 31313 J	7GB	89	80	128	111	133	4	13	2.5	2	43.2	0.83	0.73	0.40	2.43
HR 32313 J	2GD	86	80	128	116	130	4	12	2.5	2	34.0	0.35	1.7	0.96	3.6

Bore Diameter 70 – 80 mm

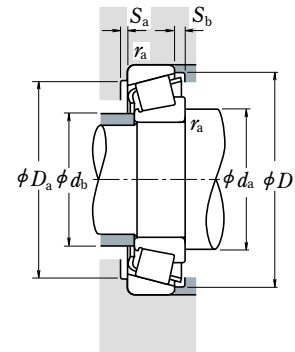
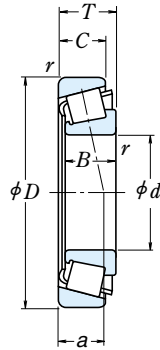

Dynamic Equivalent Load

$$P = X F_r + Y F_a$$

$F_a/F_r \leq e$		$F_a/F_r > e$	
X	Y	X	Y
1	0	0.4	Y_1

Static Equivalent Load

$$P_0 = 0.5 F_r + Y_0 F_a$$

When $F_r > 0.5 F_r + Y_0 F_a$, use $P_0 = F_r$

The values of e , Y_1 , and Y_0 are given in the table below.

d	Boundary Dimensions (mm)				Cone r min.	Cup r min.	Basic Load Ratings				Limiting Speeds (min ⁻¹)	
	D	T	B	C			(N)	(kgf)	Grease	Oil		
70	100	20	20	16	1	1	70 000	113 000	7 150	11 500	3 200	4 500
	110	25	25	19	1.5	1.5	104 000	158 000	10 600	16 100	3 200	4 300
	110	31	31	25.5	1.5	1.5	127 000	204 000	12 900	20 800	3 000	4 300
	120	37	37	29	2	1.5	177 000	262 000	18 100	26 700	3 000	4 000
	125	26.25	24	21	2	1.5	132 000	163 000	13 500	16 700	2 800	4 000
	125	33.25	31	27	2	1.5	157 000	205 000	16 100	20 900	2 800	4 000
	125	41	41	32	2	1.5	209 000	299 000	21 300	30 500	2 800	4 000
	140	39	35.5	27	3	3	177 000	229 000	18 000	23 400	2 400	3 400
	150	38	35	30	3	2.5	227 000	268 000	23 200	27 400	2 400	3 400
	150	38	35	25	3	2.5	192 000	229 000	19 600	23 300	2 200	3 200
	150	38	35	25	3	2.5	192 000	229 000	19 600	23 300	2 200	3 200
	150	54	51	42	3	2.5	300 000	390 000	30 500	39 500	2 600	3 400
150	54	51	42	3	2.5	280 000	390 000	28 600	39 500	2 400	3 400	
75	105	20	20	16	1	1	72 500	120 000	7 400	12 300	3 200	4 300
	115	25	25	19	1.5	1.5	109 000	171 000	11 100	17 400	3 000	4 000
	115	31	31	25.5	1.5	1.5	133 000	220 000	13 500	22 500	3 000	4 000
	125	37	37	29	2	2	182 000	275 000	18 600	28 100	2 800	3 800
	130	27.25	25	22	2	1.5	143 000	182 000	14 600	18 500	2 800	3 800
	130	33.25	31	27	2	1.5	165 000	219 000	16 900	22 400	2 800	3 800
	130	41	41	31	2	1.5	215 000	315 000	21 900	32 000	2 800	3 800
	160	40	37	31	3	2.5	253 000	300 000	25 800	30 500	2 400	3 200
	160	40	37	26	3	2.5	211 000	251 000	21 500	25 600	2 200	3 000
	160	40	37	26	3	2.5	211 000	251 000	21 500	25 600	2 200	3 000
	160	58	55	45	3	2.5	340 000	445 000	35 000	45 500	2 400	3 200
	160	58	55	43	3	2.5	310 000	420 000	32 000	43 000	2 200	3 200
80	110	20	20	16	1	1	75 000	128 000	7 650	13 100	3 000	4 000
	125	29	29	22	1.5	1.5	140 000	222 000	14 300	22 700	2 800	3 600
	125	36	36	29.5	1.5	1.5	172 000	282 000	17 500	28 800	2 800	3 600
	130	37	37	29	2	1.5	186 000	289 000	19 000	29 400	2 600	3 600
	140	28.25	26	22	2.5	2	157 000	195 000	16 000	19 900	2 600	3 400
	140	28.25	26	20	2.5	2	147 000	190 000	15 000	19 400	2 400	3 400
	140	35.25	33	28	2.5	2	192 000	254 000	19 600	25 900	2 600	3 400
	140	46	46	35	2.5	2	256 000	385 000	26 200	39 000	2 600	3 400
	170	42.5	39	33	3	2.5	276 000	330 000	28 200	33 500	2 200	3 000
	170	42.5	39	27	3	2.5	235 000	283 000	24 000	28 900	2 000	2 800
	170	42.5	39	27	3	2.5	235 000	283 000	24 000	28 900	2 000	2 800
	170	61.5	58	48	3	2.5	385 000	505 000	39 000	51 500	2 200	3 000
170	61.5	58	48	3	2.5	365 000	530 000	37 500	54 000	2 200	3 000	

Remarks The suffix CA represents medium-angle tapered roller bearings. Since they are designed for specific applications, please consult NSK when using bearings with suffix CA.

Bearing Numbers	ISO355 Dimension Series approx.	Abutment and Fillet Dimensions (mm)						Cone r_a max.	Cup r_a min.	Eff. Load Centers (mm) a	Constant e	Axial Load Factors		Mass (kg) approx.	
		d_a min.	d_b max.	D_a max.	D_b min.	S_a min.	S_b min.					Y_1	Y_0		
HR 32914 J	2BC	79	76	94	93	96	4	4	1	1	17.6	0.32	1.9	1.1	0.494
	4CC	81	77	101	98	105	5	6	1.5	1.5	23.7	0.43	1.4	0.76	0.869
	2CE	81	78	101	100	105	5	5.5	1.5	1.5	22.2	0.28	2.1	1.2	1.11
HR 33114 J	3DE	82	79	111	104	115	6	8	2	1.5	27.9	0.38	1.6	0.87	1.71
	3EB	82	81	116	110	118	4	5	2	1.5	25.6	0.42	1.4	0.79	1.3
	3EC	82	80	116	108	119	4	6	2	1.5	28.6	0.42	1.4	0.79	1.66
HR 33214 J	3EE	82	78	116	107	120	7	9	2	1.5	30.4	0.41	1.5	0.81	2.15
	T 7 FC070	7FC	88	79	126	106	5	12	2.5	2.5	46.4	0.87	0.69	0.38	2.55
	2GB	88	89	138	132	140	4	8	2.5	2	29.7	0.35	1.7	0.96	3.03
HR 30314 J	7GB	94	85	138	118	142	4	13	2.5	2	45.8	0.83	0.73	0.40	2.94
	7GB	94	85	138	118	142	4	13	2.5	2	45.8	0.83	0.73	0.40	2.94
	2GD	91	86	138	124	140	4	12	2.5	2	36.1	0.35	1.7	0.96	4.35
HR 32314 CJ	5GD	91	84	138	115	141	4	12	2.5	2	43.3	0.55	1.1	0.60	4.47
HR 32915 J	2BC	84	81	99	98	101	4	4	1	1	18.7	0.33	1.8	0.99	0.53
	4CC	86	82	106	103	110	5	6	1.5	1.5	25.1	0.46	1.3	0.72	0.925
	2CE	86	83	106	104	110	6	5.5	1.5	1.5	23.0	0.30	2.0	1.1	1.18
HR 33115 J	3DE	87	83	115	109	120	6	8	2	2	29.2	0.40	1.5	0.83	1.8
	4DB	87	85	121	115	124	4	5	2	1.5	27.0	0.44	1.4	0.76	1.43
	4DC	87	84	121	113	125	4	6	2	1.5	29.8	0.44	1.4	0.76	1.72
HR 33215 J	3EE	87	83	121	111	125	7	10	2	1.5	31.6	0.43	1.4	0.77	2.25
	2GB	93	95	148	141	149	4	9	2.5	2	31.8	0.35	1.7	0.96	3.63
	7GB	99	91	148	129	152	6	14	2.5	2	48.8	0.83	0.73	0.40	3.47
HR 31315 J	7GB	99	91	148	129	152	6	14	2.5	2	48.8	0.83	0.73	0.40	3.47
	2GD	96	91	148	134	149	4	13	2.5	2	38.9	0.35	1.7	0.96	5.31
	32315 CA	—	96	90	148	124	4	15	2.5	2	47.7	0.58	1.0	0.57	5.3
HR 32916 J	2BC	89	85	104	102	106	4	4	1	1	19.8	0.35	1.7	0.94	0.56
	3CC	91	89	116	112	120	6	7	1.5	1.5	26.9	0.42	1.4	0.78	1.32
	2CE	91	88	116	112	119	6	6.5	1.5	1.5	25.5	0.28	2.2	1.2	1.66
HR 33116 J	3DE	82	88	121	113	126	6	8	2	1.5	30.4	0.42	1.4	0.79	1.88
	3EB	95	91	130	124	132	4	6	2	2	28.1	0.42	1.4	0.79	1.68
	30216 CA	—	95	92	130	122	4	8	2	2	33.8	0.58	1.0	0.57	1.66
HR 32216 J	3EC	95	90	130	122	134	4	7	2	2	30.6	0.42	1.4	0.79	2.13
	3EE	95	89	130	119	135	7	11	2	2	34.8	0.43	1.4	0.78	2.93
	2GB	98	102	158	150	159	4	9.5	2.5	2	34.0	0.35	1.7	0.96	4.27
HR 30316 J	7GB	104	97	158	136	159	6	15.5	2.5	2	51.8	0.83	0.73	0.40	4.07
	7GB	104	97	158	136	159	6	15.5	2.5	2	51.8	0.83	0.73	0.40	4.07
	2GD	101	98	158	143	159	4	13.5	2.5	2	41.4	0.35	1.7	0.96	6.35
HR 32316 CJ	5GD	101	95	158	132	160	4	13.5	2.5	2	49.3	0.55	1.1	0.60	6.59

Bore Diameter 85 – 100 mm

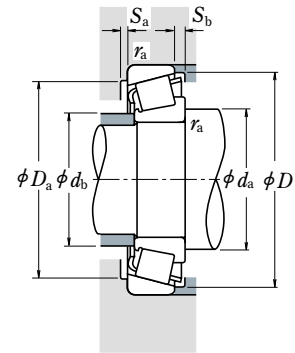
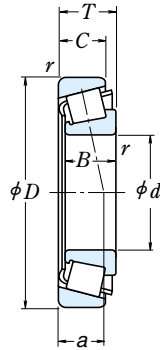

Dynamic Equivalent Load

$$P = X F_r + Y F_a$$

$F_a/F_r \leq e$		$F_a/F_r > e$	
X	Y	X	Y
1	0	0.4	Y_1

Static Equivalent Load

$$P_0 = 0.5 F_r + Y_0 F_a$$

When $F_r > 0.5 F_r + Y_0 F_a$, use $P_0 = F_r$

The values of e , Y_1 , and Y_0 are given in the table below.

d	Boundary Dimensions (mm)				Cone		Basic Load Ratings				Limiting Speeds			
	D	T	B	C	r	Cup	(N)	(kgf)	C _r	C _{0r}	C _r	C _{0r}	Grease	Oil
85	120	23	23	18	1.5	1.5	93 500	157 000	9 550	16 000	2 800	3 800		
	130	29	29	22	1.5	1.5	143 000	231 000	14 600	23 600	2 600	3 600		
	130	36	36	29.5	1.5	1.5	180 000	305 000	18 400	31 000	2 600	3 600		
	140	41	41	32	2.5	2	230 000	365 000	23 500	37 000	2 400	3 400		
	150	30.5	28	24	2.5	2	184 000	233 000	18 700	23 800	2 400	3 200		
	150	30.5	28	22	2.5	2	171 000	226 000	17 500	23 000	2 200	3 200		
	150	38.5	36	30	2.5	2	210 000	277 000	21 400	28 200	2 200	3 200		
	150	49	49	37	2.5	2	281 000	415 000	28 700	42 500	2 400	3 200		
	180	44.5	41	34	4	3	310 000	375 000	31 500	38 000	2 000	2 800		
	180	44.5	41	28	4	3	261 000	315 000	26 600	32 000	1 900	2 600		
90	140	32	32	24	2	1.5	170 000	273 000	17 300	27 800	2 400	3 200		
	140	39	39	32.5	2	1.5	220 000	360 000	22 400	37 000	2 400	3 200		
	150	45	45	35	2.5	2	259 000	405 000	26 500	41 500	2 400	3 200		
	160	32.5	30	26	2.5	2	201 000	256 000	20 500	26 100	2 200	3 000		
	160	42.5	40	34	2.5	2	256 000	350 000	26 100	35 500	2 200	3 000		
	190	46.5	43	36	4	3	345 000	425 000	35 500	43 000	1 900	2 600		
	190	46.5	43	30	4	3	264 000	315 000	26 900	32 000	1 800	2 400		
	190	46.5	43	30	4	3	264 000	315 000	26 900	32 000	1 800	2 400		
	190	67.5	64	53	4	3	450 000	590 000	46 000	60 500	2 000	2 600		
	95	130	23	23	18	1.5	1.5	98 000	172 000	10 000	17 500	2 400	3 400	
145		32	32	24	2	1.5	173 000	283 000	17 600	28 900	2 400	3 200		
145		39	39	32.5	2	1.5	231 000	390 000	23 500	39 500	2 400	3 200		
160		46	46	38	3	3	283 000	445 000	28 800	45 500	2 200	3 000		
170		34.5	32	27	3	2.5	223 000	286 000	22 800	29 200	2 200	2 800		
170		45.5	43	37	3	2.5	289 000	400 000	29 500	40 500	2 200	2 800		
200		49.5	45	38	4	3	370 000	455 000	38 000	46 500	1 900	2 600		
200		49.5	45	36	4	3	350 000	435 000	35 500	44 000	1 800	2 400		
200		49.5	45	32	4	3	310 000	375 000	31 500	38 500	1 700	2 400		
200		49.5	45	32	4	3	310 000	375 000	31 500	38 500	1 700	2 400		
100	140	25	25	20	1.5	1.5	117 000	205 000	12 000	20 900	2 200	3 200		
	145	24	22.5	17.5	3	3	113 000	163 000	11 500	16 600	2 200	3 000		
	150	32	32	24	2	1.5	176 000	294 000	17 900	30 000	2 200	3 000		
	150	39	39	32.5	2	1.5	235 000	405 000	24 000	41 500	2 200	3 000		
	165	52	52	40	2.5	2	315 000	515 000	32 500	52 500	2 000	2 800		
	180	37	34	29	3	2.5	255 000	330 000	26 000	34 000	2 000	2 600		
	180	49	46	39	3	2.5	325 000	450 000	33 000	46 000	2 000	2 600		
	180	63	63	48	3	2.5	410 000	635 000	42 000	65 000	2 000	2 600		
	215	51.5	47	39	4	3	425 000	525 000	43 000	53 500	1 700	2 400		
	215	56.5	51	35	4	3	385 000	505 000	39 000	51 500	1 500	2 200		
215	77.5	73	60	4	3	565 000	755 000	57 500	77 000	1 700	2 400			

Bearing Numbers	ISO355 Dimension Series approx.	Abutment and Fillet Dimensions (mm)						Cone		Eff. Load Centers (mm) a	Constant e	Axial Load Factors		Mass (kg) approx.	
		d _a min.	d _b max.	D _a max.	D _b min.	S _a min.	S _b min.	r _a min.	r _a max.			Y ₁	Y ₀		
HR 32917 J	2BC	96	92	111	111	115	5	5	1.5	1.5	20.9	0.33	1.8	1.0	0.8
HR 32017 XJ	4CC	96	94	121	116	125	6	7	1.5	1.5	28.2	0.44	1.4	0.75	1.38
HR 33017 J	2CE	96	94	121	117	125	6	6.5	1.5	1.5	26.5	0.29	2.1	1.1	1.75
HR 33117 J	3DE	100	94	130	122	135	7	9	2	2	32.7	0.41	1.5	0.81	2.51
HR 30217 J	3EB	100	97	140	133	141	5	6.5	2	2	30.3	0.42	1.4	0.79	2.12
30217 CA	—	100	98	140	131	142	5	8.5	2	2	36.2	0.58	1.0	0.57	2.07
HR 32217 J	3EC	100	96	140	131	142	5	8.5	2	2	33.9	0.42	1.4	0.79	2.64
HR 33217 J	3FE	100	95	140	129	144	7	12	2	2	37.3	0.42	1.4	0.79	3.57
HR 30317 J	2GB	106	108	166	157	167	5	10.5	3	2.5	35.8	0.35	1.7	0.96	5.08
HR 30317 DJ	7GB	113	103	166	144	169	6	16.5	3	2.5	55.4	0.83	0.73	0.40	4.88
HR 31317 J	7GB	113	103	166	144	169	6	16.5	3	2.5	55.4	0.83	0.73	0.40	4.88
HR 32317 J	2GD	110	104	166	151	167	5	14.5	3	2.5	43.6	0.35	1.7	0.96	7.31
HR 32918 J	2BC	101	97	116	116	120	5	5	1.5	1.5	22.0	0.34	1.8	0.96	0.838
HR 32018 XJ	3CC	102	99	131	124	134	6	8	2	1.5	29.7	0.42	1.4	0.78	1.78
HR 33018 J	2CE	102	99	131	129	135	7	6.5	2	1.5	27.9	0.27	2.2	1.2	2.21
HR 33118 J	3DE	105	100	140	132	144	7	10	2	2	35.2	0.40	1.5	0.83	3.14
HR 30218 J	3FB	105	103	150	141	150	5	6.5	2	2	31.7	0.42	1.4	0.79	2.6
HR 32218 J	3FC	105	102	150	139	152	5	8.5	2	2	36.2	0.42	1.4	0.79	3.41
HR 30318 J	2GB	111	114	176	176	176	5	10.5	3	2.5	37.3	0.35	1.7	0.96	5.91
HR 30318 DJ	7GB	118	110	176	152	179	6	16.5	3	2.5	58.7	0.83	0.73	0.40	5.52
HR 31318 J	7GB	118	110	176	152	179	6	16.5	3	2.5	58.7	0.83	0.73	0.40	5.52
HR 32318 J	2GD	115	109	176	158	177	5	14.5	3	2.5	46.5	0.35	1.7	0.96	8.6
HR 32919 J	2BC	106	102	121	121	125	5	5	1.5	1.5	23.2	0.36	1.7	0.92	0.877
HR 32019 XJ	4CC	107	104	136	131	140	6	8	2	1.5	31.2	0.44	1.4	0.75	1.88
HR 33019 J	2CE	107	103	136	133	139	7	6.5	2	1.5	28.6	0.28	2.2	1.2	2.3
T 2 ED095	2ED	113	108	146	141	152	6	8	2.5	2.5	34.5	0.34	1.8	0.97	3.74
HR 30219 J	3FB	113	110	158	150	159	5	7.5	2.5	2	33.7	0.42	1.4	0.79	3.13
HR 32219 J	3FC	113	108	158	147	161	5	8.5	2.5	2	39.3	0.42	1.4	0.79	4.22
HR 30319 J	2GB	116	119	186	172	184	5	11.5	3	2.5	38.6	0.35	1.7	0.96	6.92
30319 CA	—	116	119	186	168	188	5	13.5	3	2.5	48.6	0.54	1.1	0.61	6.71
HR 30319 DJ	7GB	123	115	186	158	187	6	17.5	3	2.5	61.9	0.83	0.73	0.40	6.64
HR 31319 J	7GB	123	115	186	158	187	6	17.5	3	2.5	61.9	0.83	0.73	0.40	6.64
HR 32319 J	2GD	120	115	186	167	186	5	16.5	3	2.5	48.6	0.35	1.7	0.96	10.4
HR 32920 J	2CC	111	109	132	132	134	5	5	1.5	1.5	24.2	0.33	1.8	1.0	1.18
T 4 CB100	4CB	118	108	135	135	142	6	6.5	2.5	2.5	30.1	0.47	1.3	0.70	1.18
HR 32020 XJ	4CC	112	109	141	136	144	6	8	2	1.5	32.5	0.46	1.3	0.72	1.95
HR 33020 J	2CE	112	107	141	137	143	7	6.5	2	1.5	29.3	0.29	2.1	1.2	2.38
HR 33120 J	3EE	115	110	155	144	159	8	12	2	2	40.5	0.41	1.5	0.81	4.32
HR 30220 J	3FB	118	116	168	158	168	5	8	2.5	2	36.1	0.42	1.4	0.79	3.78
HR 32220 J	3FC	118	115	168	155	171	5	10	2.5	2	41.5	0.42	1.4	0.79	5.05
HR 33220 J	3FE	118	113	168	152	172	10	15	2.5	2	46.0	0.40	1.5	0.82	6.76
HR 30320 J	2GB	121	128	201	185	197	5	12.5	3	2.5	41.4	0.35	1.7	0.96	8.41
HR 31320 J	7GB	136	125	201	169	202	7	21.5	3	2.5	67.7	0.83	0.73	0.40	9.02
HR 32320 J	2GD	125	125	201	178	200	5	17.5	3	2.5	53.2	0.35	1.7	0.96	12.7

Remarks The suffix CA represents medium-angle tapered roller bearings. Since they are designed for specific applications, please consult NSK when using bearings with suffix CA.

Bore Diameter 105 – 130 mm

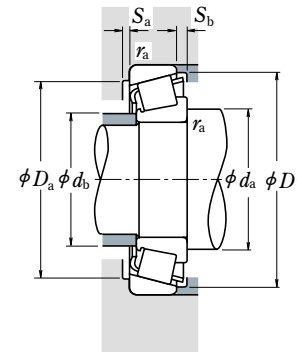
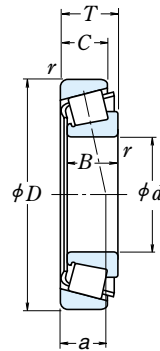

Dynamic Equivalent Load

$$P = X F_r + Y F_a$$

$F_a/F_r \leq e$		$F_a/F_r > e$	
X	Y	X	Y
1	0	0.4	Y_1

Static Equivalent Load

$$P_0 = 0.5 F_r + Y_0 F_a$$

When $F_r > 0.5 F_r + Y_0 F_a$, use $P_0 = F_r$

The values of e , Y_1 , and Y_0 are given in the table below.

Boundary Dimensions (mm)							Basic Load Ratings				Limiting Speeds		
d	D	T	B	C	Cone r	Cup r	(N)		(kgf)		Grease	Oil	
							C_r	C_{0r}	C_r	C_{0r}	(min^{-1})		
105	145	25	25	20	1.5	1.5	119 000	212 000	12 100	21 600	2 200	3 000	
	160	35	35	26	2.5	2	204 000	340 000	20 800	34 500	2 000	2 800	
	160	43	43	34	2.5	2	256 000	435 000	26 100	44 000	2 000	2 800	
	190	39	36	30	3	2.5	280 000	365 000	28 500	37 500	1 900	2 600	
	190	53	50	43	3	2.5	360 000	510 000	37 000	52 000	1 900	2 600	
	225	53.5	49	41	4	3	455 000	565 000	46 500	57 500	1 600	2 200	
	225	58	53	36	4	3	415 000	540 000	42 000	55 000	1 500	2 000	
	225	81.5	77	63	4	3	670 000	925 000	68 000	94 500	1 700	2 200	
	110	150	25	25	20	1.5	1.5	123 000	224 000	12 500	22 800	2 200	2 800
		170	38	38	29	2.5	2	236 000	390 000	24 000	40 000	2 000	2 600
170		47	47	37	2.5	2	294 000	515 000	30 000	52 500	2 000	2 600	
180		56	56	43	2.5	2	365 000	610 000	37 500	62 000	1 900	2 600	
200		41	38	32	3	2.5	315 000	420 000	32 000	43 000	1 800	2 400	
200		56	53	46	3	2.5	400 000	565 000	40 500	57 500	1 800	2 400	
240		54.5	50	42	4	3	485 000	595 000	49 500	60 500	1 500	2 000	
240		63	57	38	4	3	470 000	605 000	48 000	62 000	1 400	1 900	
240		84.5	80	65	4	3	675 000	910 000	68 500	93 000	1 500	2 000	
120		165	29	29	23	1.5	1.5	161 000	291 000	16 400	29 700	1 900	2 600
	170	27	25	19.5	3	3	153 000	243 000	51 600	24 800	1 800	2 600	
	180	38	38	29	2.5	2	242 000	405 000	24 600	41 000	1 800	2 400	
	180	48	48	38	2.5	2	300 000	540 000	30 500	55 000	1 800	2 600	
	200	62	62	48	2.5	2	460 000	755 000	46 500	77 000	1 700	2 400	
	215	43.5	40	34	3	2.5	335 000	450 000	34 000	46 000	1 600	2 200	
	215	61.5	58	50	3	2.5	440 000	635 000	44 500	65 000	1 600	2 200	
	260	59.5	55	46	4	3	535 000	655 000	54 500	67 000	1 400	1 900	
	260	68	62	42	4	3	560 000	730 000	57 000	74 500	1 300	1 800	
	260	90.5	86	69	4	3	770 000	1 060 000	78 500	108 000	1 400	1 900	
130	180	32	30	26	2	1.5	167 000	281 000	17 000	28 600	1 800	2 400	
	180	32	32	25	2	1.5	200 000	365 000	20 400	37 500	1 800	2 400	
	185	29	27	21	3	3	183 000	296 000	18 600	30 000	1 700	2 400	
	200	45	45	34	2.5	2	320 000	535 000	32 500	54 500	1 600	2 200	
	200	55	55	43	2.5	2	395 000	715 000	40 500	73 000	1 700	2 200	
	230	43.75	40	34	4	3	375 000	505 000	38 000	51 500	1 500	2 000	
	230	67.75	64	54	4	3	530 000	790 000	54 000	80 500	1 500	2 000	
	280	63.75	58	49	5	4	545 000	675 000	56 000	68 500	1 300	1 800	
	280	63.75	58	49	5	4	650 000	820 000	66 000	83 500	1 300	1 800	
	280	72	66	44	5	4	625 000	820 000	63 500	83 500	1 200	1 700	
280	98.75	93	78	5	4	830 000	1 150 000	84 500	117 000	1 300	1 800		

Bearing Numbers	ISO355 Dimension Series approx.	Abutment and Fillet Dimensions (mm)								Eff. Load Centers (mm) a	Constant e	Axial Load Factors		Mass (kg) approx.	
		d_a min.	d_b max.	D_a max.	D_b min.	S_a min.	S_b min.	Cone r_a max.	Cup r_b max.			Y_1	Y_0		
HR 32921 J	2CC	116	114	137	137	140	5	5	1.5	1.5	25.3	0.34	1.8	0.96	1.23
HR 32021 XJ	4DC	120	115	150	144	154	6	9	2	2	34.3	0.44	1.4	0.74	2.48
HR 33021 J	2DE	120	115	150	146	153	7	9	2	2	30.9	0.28	2.1	1.2	3.03
HR 30221 J	3FB	123	123	178	166	177	6	9	2.5	2	38.1	0.42	1.4	0.79	4.51
HR 32221 J	3FC	123	120	178	162	180	5	10	2.5	2	44.8	0.42	1.4	0.79	6.25
HR 30321 J	2GB	126	133	211	195	206	6	12.5	3	2.5	43.3	0.35	1.7	0.96	9.52
HR 31321 J	7GB	141	130	211	177	211	7	22	3	2.5	70.2	0.83	0.73	0.40	10
HR 32321 J	2GD	130	129	211	186	209	6	18.5	3	2.5	55.2	0.35	1.7	0.96	14.9
HR 32922 J	2CC	121	119	142	142	145	5	5	1.5	1.5	26.5	0.36	1.7	0.93	1.29
HR 32022 XJ	4DC	125	121	160	153	163	7	9	2	2	35.9	0.43	1.4	0.77	3.09
HR 33022 J	2DE	125	121	160	153	161	7	10	2	2	33.7	0.29	2.1	1.2	3.84
HR 33122 J	3EE	125	121	170	156	174	9	13	2	2	44.1	0.42	1.4	0.79	5.54
HR 30222 J	3FB	128	129	188	175	187	6	9	2.5	2	40.2	0.42	1.4	0.79	5.28
HR 32222 J	3FC	128	127	188	171	190	5	10	2.5	2	47.2	0.42	1.4	0.79	7.35
HR 30322 J	2GB	131	143	226	208	220	6	12.5	3	2.5	45.1	0.35	1.7	0.96	11
HR 31322 J	7GB	146	136	226	191	224	7	25	3	2.5	74.8	0.83	0.73	0.40	12.3
HR 32322 J	2GD	135	139	226	201	222	6	19.5	3	2.5	58.6	0.35	1.7	0.96	17.1
HR 32924 J	2CC	131	129	156	155	160	6	6	1.5	1.5	29.2	0.35	1.7	0.95	1.8
T 4 CB120	4CB	138	129	158	158	164	7	7.5	2.5	2.5	35.0	0.47	1.3	0.70	1.78
HR 32024 XJ	4DC	135	131	170	162	173	7	9	2	2	39.7	0.46	1.3	0.72	3.27
HR 33024 J	2DE	135	130	168	161	171	6	10	2	2	36.0	0.31	2.0	1.1	4.2
HR 33124 J	3FE	135	133	190	173	192	9	14	2	2	47.9	0.40	1.5	0.83	7.67
HR 30224 J	4FB	138	141	203	190	201	6	9.5	2.5	2	44.4	0.44	1.4	0.76	6.28
HR 32224 J	4FD	138	137	203	181	204	6	11.5	2.5	2	52.1	0.44	1.4	0.76	9.0
HR 30324 J	2GB	141	154	246	223	237	6	13.5	3	2.5	50.0	0.35	1.7	0.96	13.9
HR 31324 J	7GB	156	148	246	206	244	9	26	3	2.5	81.7	0.83	0.73	0.40	15.6
HR 32324 J	2GD	145	149	246	216	239	6	21.5	3	2.5	62.5	0.35	1.7	0.96	21.8
32926	—	142	141	171	168	175	6	6	2	1.5	34.7	0.36	1.7	0.92	2.25
HR 32926 J	2CC	142	140	170	168	173	6	7	2	1.5	31.4	0.34	1.8	0.97	2.46
T 4 CB130	4CB	148	141	171	171	179	8	8	2.5	2.5	37.5	0.47	1.3	0.70	2.32
HR 32026 XJ	4EC	145	144	190	179	192	8	11	2	2	43.9	0.43	1.4	0.76	5.06
HR 33026 J	2EE	145	144	188	179	192	8	12	2	2	42.4	0.34	1.8	0.97	6.25
HR 30226 J	4FB	151	151	216	205	217	7	9.5	3	2.5	45.9	0.44	1.4	0.76	7.25
HR 32226 J	4FD	151	147	216	196	219	7	13.5	3	2.5	57.0	0.44	1.4	0.76	11.3
30326	—	157	168	262	239	255	8	14.5	4	3	53.9	0.36	1.7	0.92	16.6
HR 30326 J	2GB	157	166	262	241	255	8	14.5	4	3	52.8	0.35	1.7	0.96	17.2
HR 31326 J	7GB	174	159	262	220	261	9	28	4	3	87.1	0.83	0.73	0.40	18.8
32326	—	162	165	262	233	263	8	20.5	4	3	69.2	0.36	1.7	0.92	26.6

Bore Diameter 140 – 170 mm

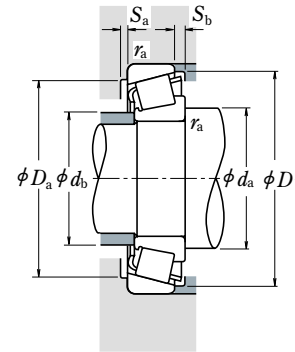
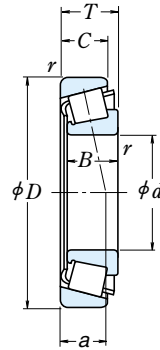

Dynamic Equivalent Load

$$P = XF_r + YF_a$$

$F_a/F_r \leq e$		$F_a/F_r > e$	
X	Y	X	Y
1	0	0.4	Y_1

Static Equivalent Load

$$P_0 = 0.5F_r + Y_0F_a$$

When $F_r > 0.5F_r + Y_0F_a$, use $P_0 = F_r$

The values of e , Y_1 , and Y_0 are given in the table below.

d	Boundary Dimensions (mm)				Cone r min.	Cup r min.	Basic Load Ratings				Limiting Speeds (min ⁻¹)		
	D	T	B	C			(N)	{kgf}		Grease	Oil		
140	190	32	32	25	2	1.5	206 000	390 000	21 000	39 500	1 700	2 200	
	210	45	45	34	2.5	2	325 000	555 000	33 000	57 000	1 600	2 200	
	210	56	56	44	2.5	2	410 000	770 000	42 000	78 500	1 600	2 200	
	250	45.75	42	36	4	3	390 000	515 000	40 000	52 500	1 400	1 900	
	250	71.75	68	58	4	3	610 000	915 000	62 000	93 500	1 400	1 900	
	300	67.75	62	53	5	4	740 000	945 000	75 500	96 500	1 200	1 700	
	300	77	70	47	5	4	695 000	955 000	71 000	97 500	1 100	1 500	
	300	107.75	102	85	5	4	985 000	1 440 000	101 000	147 000	1 200	1 600	
	150	210	38	36	31	2.5	2	247 000	440 000	25 200	45 000	1 500	2 000
		210	38	38	30	2.5	2	281 000	520 000	28 600	53 000	1 500	2 000
		225	48	48	36	3	2.5	375 000	650 000	38 000	66 500	1 400	2 000
		225	59	59	46	3	2.5	435 000	805 000	44 000	82 000	1 400	2 000
270		49	45	38	4	3	485 000	665 000	49 000	67 500	1 300	1 800	
270		77	73	60	4	3	705 000	1 080 000	71 500	110 000	1 300	1 800	
320		72	65	55	5	4	690 000	860 000	70 000	87 500	1 100	1 500	
320		72	65	55	5	4	825 000	1 060 000	84 500	108 000	1 100	1 600	
320		82	75	50	5	4	790 000	1 100 000	80 500	112 000	1 000	1 400	
320		114	108	90	5	4	1 120 000	1 700 000	114 000	174 000	1 100	1 500	
160		220	38	38	30	2.5	2	296 000	570 000	30 000	58 000	1 400	1 900
		240	51	51	38	3	2.5	425 000	750 000	43 500	76 500	1 300	1 800
	290	52	48	40	4	3	530 000	730 000	54 000	74 500	1 200	1 600	
	290	84	80	67	4	3	795 000	1 220 000	81 000	125 000	1 200	1 600	
	340	75	68	58	5	4	765 000	960 000	78 000	98 000	1 000	1 400	
	340	75	68	58	5	4	870 000	1 110 000	89 000	113 000	1 100	1 400	
	340	75	68	48	5	4	675 000	875 000	69 000	89 000	950	1 300	
	340	121	114	95	5	4	1 210 000	1 770 000	123 000	181 000	1 000	1 400	
	170	230	38	36	31	2.5	2.5	258 000	485 000	26 300	49 500	1 300	1 800
		230	38	38	30	2.5	2	294 000	560 000	30 000	57 000	1 400	1 800
		260	57	57	43	3	2.5	505 000	890 000	51 500	90 500	1 200	1 700
		310	57	52	43	5	4	630 000	885 000	64 000	90 000	1 100	1 500
310		91	86	71	5	4	930 000	1 450 000	94 500	148 000	1 100	1 500	
360		80	72	62	5	4	845 000	1 080 000	86 000	110 000	950	1 300	
360		80	72	62	5	4	960 000	1 230 000	98 000	125 000	1 000	1 300	
360		80	72	50	5	4	760 000	1 040 000	77 500	106 000	900	1 200	
360		127	120	100	5	4	1 370 000	2 050 000	140 000	209 000	1 000	1 300	

Bearing Numbers	ISO355 Dimension Series approx.	Abutment and Fillet Dimensions (mm)						Cone r max.	Cup r max.	Eff. Load Centers (mm) a	Constant e	Axial Load Factors		Mass (kg) approx.	
		d _a min.	d _b max.	D _a max.	D _b min.	S _a min.	S _b min.					Y ₁	Y ₀		
HR 32928 J HR 32028 XJ HR 33028 J	2CC	152	150	180	178	184	6	7	2	1.5	33.6	0.36	1.7	0.92	2.64
	4DC	155	152	200	189	202	8	11	2	2	46.6	0.46	1.3	0.72	5.32
	2DE	155	153	198	189	202	7	12	2	2	45.5	0.36	1.7	0.92	6.74
HR 30228 J HR 32228 J HR 30328 J	4FB	161	164	236	221	234	7	9.5	3	2.5	48.9	0.44	1.4	0.76	8.74
	4FD	161	159	236	213	238	9	13.5	3	2.5	60.5	0.44	1.4	0.76	14.3
	2GB	167	177	282	256	273	9	14.5	4	3	55.7	0.35	1.7	0.96	21.1
HR 31328 J 32328	7GB	184	174	282	236	280	9	30	4	3	92.9	0.83	0.73	0.40	28.5
	—	172	177	282	246	281	9	22.5	4	3	76.4	0.37	1.6	0.88	33.9
32930 HR 32930 J HR 32030 XJ	—	165	162	200	195	201	7	7	2	2	36.7	0.33	1.8	1.0	3.8
	2DC	165	163	198	196	202	7	8	2	2	36.5	0.33	1.8	1.0	4.05
	4EC	168	164	213	202	216	8	12	2.5	2	49.8	0.46	1.3	0.72	6.6
HR 33030 J HR 30230 J HR 32230 J	2EE	168	165	213	203	217	8	13	2.5	2	48.7	0.36	1.7	0.90	8.07
	2GB	171	175	256	236	250	7	11	3	2.5	51.3	0.44	1.4	0.76	11.2
	4GD	171	171	256	228	254	8	17	3	2.5	64.7	0.44	1.4	0.76	17.8
30330 HR 30330 J HR 31330 J 32330	—	177	193	302	275	292	8	17	4	3	61.4	0.36	1.7	0.92	24.2
	2GB	177	190	302	276	292	8	17	4	3	60.0	0.35	1.7	0.96	25
	7GB	194	187	302	253	300	9	32	4	3	99.3	0.83	0.73	0.40	28.5
32330	—	182	191	302	262	297	8	24	4	3	81.5	0.37	1.6	0.88	41.4
HR 32932 J HR 32032 XJ HR 30232 J	2DC	175	173	208	206	212	7	8	2	2	38.7	0.35	1.7	0.95	4.32
	4EC	178	175	228	216	231	8	13	2.5	2	53.0	0.46	1.3	0.72	7.93
	4GB	181	189	276	253	269	8	12	3	2.5	55.0	0.44	1.4	0.76	13.7
HR 32232 J 30332 HR 30332 J	4GD	181	184	276	243	274	10	17	3	2.5	70.5	0.44	1.4	0.76	22.7
	—	187	205	322	293	311	10	17	4	3	64.6	0.36	1.7	0.92	28.4
	2GB	187	201	322	293	310	10	17	4	3	62.9	0.35	1.7	0.96	29.2
30332 D 32332	—	196	198	322	270	313	9	27	4	3	99.4	0.81	0.74	0.41	27.5
	—	192	202	322	281	319	10	26	4	3	87.1	0.37	1.6	0.88	48.3
32934 HR 32934 J HR 32034 XJ	—	185	183	220	216	223	7	7	2	2	41.6	0.36	1.7	0.90	4.3
	3DC	185	180	218	215	222	7	8	2	2	41.7	0.38	1.6	0.86	4.44
	4EC	188	187	248	232	249	10	14	2.5	2	56.6	0.44	1.4	0.74	10.6
HR 30234 J HR 32234 J 30334	4GB	197	202	292	273	288	8	14	4	3	59.4	0.44	1.4	0.76	17.1
	4GD	197	197	292	262	294	10	20	4	3	76.4	0.44	1.4	0.76	28
	—	197	221	342	312	332	10	18	4	3	70.1	0.37	1.6	0.90	33.5
HR 30334 J 30334 D 32334	2GB	197	214	342	310	329	10	18	4	3	67.3	0.35	1.7	0.96	34.5
	—	206	215	342	288	332	10	30	4	3	107.3	0.81	0.74	0.41	33.4
	—	202	213	342	297	337	10	27	4	3	91.3	0.37	1.6	0.88	57

Bore Diameter 180 – 240 mm

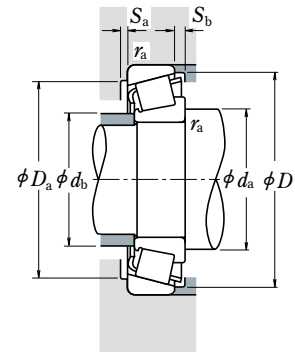
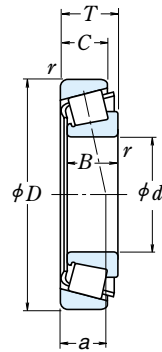

Dynamic Equivalent Load

$$P = XF_r + YF_a$$

$F_a/F_r \leq e$		$F_a/F_r > e$	
X	Y	X	Y
1	0	0.4	Y_1

Static Equivalent Load

$$P_0 = 0.5F_r + Y_0F_a$$

When $F_r > 0.5F_r + Y_0F_a$, use $P_0 = F_r$

The values of e , Y_1 , and Y_0 are given in the table below.

Boundary Dimensions (mm)					Basic Load Ratings				Limiting Speeds				
d	D	T	B	C	Cone Cup		(N)		(min ⁻¹)				
					r	r_{min}	C_r	C_{0r}	C_r	C_{0r}	Grease	Oil	
							{kgf}						
180	250	45	45	34	2.5	2	350 000	685 000	36 000	69 500	1 300	1 700	
	280	64	64	48	3	2.5	640 000	1 130 000	65 000	115 000	1 200	1 600	
	320	57	52	43	5	4	650 000	930 000	66 000	95 000	1 100	1 400	
	320	91	86	71	5	4	960 000	1 540 000	98 000	157 000	1 100	1 400	
	380	83	75	64	5	4	935 000	1 230 000	95 500	126 000	900	1 300	
	380	83	75	53	5	4	820 000	1 120 000	83 500	114 000	850	1 200	
	380	134	126	106	5	4	1 520 000	2 290 000	155 000	234 000	950	1 300	
	190	260	45	45	34	2.5	2	365 000	715 000	37 000	73 000	1 200	1 600
		290	64	64	48	3	2.5	650 000	1 170 000	66 000	119 000	1 100	1 500
		340	60	55	46	5	4	715 000	1 020 000	73 000	104 000	1 000	1 300
340		97	92	75	5	4	1 110 000	1 770 000	113 000	181 000	1 000	1 400	
200	400	86	78	65	6	5	1 010 000	1 340 000	103 000	136 000	850	1 200	
	400	140	132	109	6	5	1 660 000	2 580 000	169 000	263 000	850	1 200	
	280	51	48	41	3	2.5	410 000	780 000	42 000	80 000	1 100	1 500	
	280	51	51	39	3	2.5	480 000	935 000	48 500	95 000	1 100	1 500	
	310	70	70	53	3	2.5	760 000	1 370 000	77 500	139 000	1 000	1 400	
	360	64	58	48	5	4	795 000	1 120 000	81 000	114 000	950	1 300	
	360	104	98	82	5	4	1 210 000	1 920 000	123 000	196 000	950	1 300	
	420	89	80	67	6	5	1 030 000	1 390 000	105 000	142 000	850	1 200	
	420	89	80	56	6	5	965 000	1 330 000	98 500	136 000	750	1 000	
	420	146	138	115	6	5	1 820 000	2 870 000	185 000	292 000	800	1 100	
220	300	51	51	39	3	2.5	490 000	990 000	50 000	101 000	1 000	1 400	
	340	76	76	57	4	3	885 000	1 610 000	90 500	164 000	950	1 300	
	400	72	65	54	5	4	810 000	1 150 000	82 500	117 000	850	1 100	
	400	114	108	90	5	4	1 340 000	2 210 000	137 000	225 000	850	1 100	
	460	97	88	73	6	5	1 430 000	1 990 000	146 000	203 000	750	1 000	
	460	154	145	122	6	5	2 020 000	3 200 000	206 000	325 000	750	1 000	
240	320	51	51	39	3	2.5	500 000	1 040 000	51 000	107 000	950	1 300	
	360	76	76	57	4	3	920 000	1 730 000	94 000	177 000	850	1 200	
	440	79	72	60	5	4	990 000	1 400 000	101 000	142 000	750	1 000	
	440	127	120	100	5	4	1 630 000	2 730 000	166 000	278 000	750	1 000	
	500	105	95	80	6	5	1 660 000	2 340 000	169 000	238 000	670	950	
	500	165	155	132	6	5	2 520 000	4 100 000	257 000	415 000	670	900	

Bearing Numbers	ISO355 Dimension Series approx.	Abutment and Fillet Dimensions (mm)						Cone Cup	Eff. Load Centers (mm) a	Constant e	Axial Load Factors		Mass (kg) approx.		
		d_a min.	d_b max.	D_a max.	D_b min.	S_a min.	S_b min.				Y_1	Y_0			
HR 32936 J HR 32036 XJ HR 30236 J	4DC	195	192	240	227	241	8	11	2	2	53.9	0.48	1.3	0.69	6.56
	3FD	198	199	268	248	267	10	16	2.5	2	60.4	0.42	1.4	0.78	14.3
	4GB	207	210	302	281	297	9	14	4	3	61.8	0.45	1.3	0.73	17.8
HR 32236 J 30336 30336 D 32336	4GD	207	205	302	270	303	10	20	4	3	78.9	0.45	1.3	0.73	29.8
	—	207	233	362	324	345	10	19	4	3	72.5	0.36	1.7	0.92	39.3
	—	216	229	362	304	352	10	30	4	3	113.1	0.81	0.74	0.41	38.5
	—	212	225	362	310	353	10	28	4	3	96.6	0.37	1.6	0.88	66.8
HR 32938 J HR 32038 XJ HR 30238 J	4DC	205	201	250	237	251	8	11	2	2	55.3	0.48	1.3	0.69	6.83
	4FD	208	209	278	258	279	10	16	2.5	2	63.4	0.44	1.4	0.75	14.9
	4GB	217	223	322	302	318	9	14	4	3	65.6	0.44	1.4	0.76	21.4
HR 32238 J 30338 32338	4GD	217	216	322	290	323	10	22	4	3	80.5	0.44	1.4	0.76	35.2
	—	223	248	378	346	366	11	21	5	4	76.1	0.36	1.7	0.92	46
	—	229	243	378	332	375	11	31	5	4	102.7	0.37	1.6	0.88	78.9
32940 HR 32940 J HR 32040 XJ	—	218	217	268	256	269	9	10	2.5	2	53.4	0.37	1.6	0.88	9.26
	3EC	218	216	268	258	271	9	12	2.5	2	54.2	0.39	1.5	0.84	9.65
	4FD	218	221	298	277	297	11	17	2.5	2	67.4	0.43	1.4	0.77	18.9
HR 30240 J HR 32240 J 30340	4GB	227	236	342	318	336	10	16	4	3	69.1	0.44	1.4	0.76	25.5
	3GD	227	230	342	305	340	11	22	4	3	85.1	0.41	1.5	0.81	42.6
	—	233	253	398	346	368	11	22	5	4	81.4	0.37	1.6	0.88	52.3
30340 D 32340	—	244	253	398	336	385	11	33	5	4	122.9	0.81	0.74	0.41	49.6
	—	239	253	398	346	392	11	31	5	4	106.7	0.37	1.6	0.88	90.9
HR 32944 J HR 32044 XJ 30244	3EC	238	235	288	278	293	9	12	2.5	2	59.2	0.43	1.4	0.78	10.3
	4FD	241	244	326	303	326	12	19	3	2.5	73.6	0.43	1.4	0.77	24.4
	—	247	267	382	350	367	11	18	4	3	74.7	0.40	1.5	0.82	33.6
32244 30344 32344	—	247	260	382	340	377	12	24	4	3	93.0	0.40	1.5	0.82	57.4
	—	253	283	438	390	414	12	24	5	4	85.4	0.36	1.7	0.92	72.4
	—	259	274	438	372	421	12	32	5	4	114.9	0.37	1.6	0.88	114
HR 32948 J HR 32048 XJ 30248	4EC	258	255	308	297	314	9	12	2.5	2	65.1	0.46	1.3	0.72	11.1
	4FD	261	262	346	321	346	12	19	3	2.5	79.1	0.46	1.3	0.72	26.2
	—	267	288	422	384	408	11	19	4	3	85.1	0.44	1.4	0.74	45.2
32248 30348 32348	—	267	285	422	374	416	12	27	4	3	102.5	0.40	1.5	0.82	78
	—	273	308	478	422	447	12	25	5	4	92.8	0.36	1.7	0.92	92.6
	—	279	301	478	410	464	12	33	5	4	123.2	0.37	1.6	0.88	145

Bore Diameter 260 – 440 mm

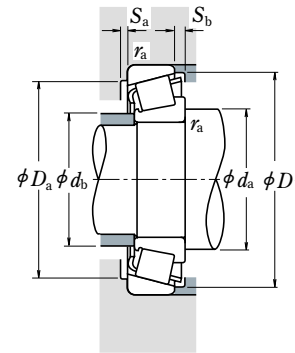
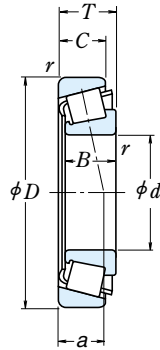

Dynamic Equivalent Load

$$P = X F_r + Y F_a$$

$F_a/F_r \leq e$		$F_a/F_r > e$	
X	Y	X	Y
1	0	0.4	Y_1

Static Equivalent Load

$$P_0 = 0.5 F_r + Y_0 F_a$$

When $F_r > 0.5 F_r + Y_0 F_a$, use $P_0 = F_r$

The values of e , Y_1 , and Y_0 are given in the table below.

d	Boundary Dimensions (mm)				Cone		Basic Load Ratings				Limiting Speeds	
	D	T	B	C	r	Cup	(N)	{kgf}		Grease	Oil	
					min.		C_r	C_{0r}	C_r	C_{0r}		
260	360	63.5	63.5	48	3	2.5	730 000	1 450 000	74 500	148 000	850	1 100
	400	87	87	65	5	4	1 160 000	2 160 000	118 000	220 000	800	1 100
	480	89	80	67	6	5	1 190 000	1 700 000	121 000	174 000	670	900
280	480	137	130	106	6	5	1 900 000	3 300 000	194 000	335 000	670	950
	540	113	102	85	6	6	1 870 000	2 640 000	190 000	269 000	630	850
	540	176	165	136	6	6	2 910 000	4 800 000	297 000	490 000	630	850
300	420	76	72	62	4	3	895 000	1 820 000	91 000	186 000	710	950
	420	76	76	57	4	3	1 010 000	2 100 000	103 000	214 000	710	950
	460	100	100	74	5	4	1 440 000	2 700 000	147 000	275 000	670	900
320	540	96	85	71	6	5	1 440 000	2 100 000	147 000	214 000	600	800
	540	149	140	115	6	5	2 220 000	3 700 000	226 000	380 000	600	800
	440	76	72	63	4	3	900 000	1 880 000	92 000	192 000	970	900
340	440	76	76	57	4	3	1 040 000	2 220 000	106 000	227 000	670	900
	480	100	100	74	5	4	1 510 000	2 910 000	153 000	297 000	630	850
	580	104	92	75	6	5	1 640 000	2 420 000	168 000	247 000	530	750
360	580	159	150	125	6	5	2 860 000	5 050 000	292 000	515 000	530	750
	670	210	200	170	7.5	7.5	4 200 000	7 100 000	430 000	725 000	480	670
	460	76	72	63	4	3	910 000	1 940 000	93 000	197 000	630	850
380	460	76	76	57	4	3	1 050 000	2 220 000	107 000	226 000	630	850
	520	112	106	92	6	5	1 650 000	3 400 000	168 000	345 000	560	750
	480	76	72	62	4	3	945 000	2 100 000	96 500	214 000	600	800
400	480	76	76	57	4	3	1 080 000	2 340 000	110 000	239 000	560	800
	540	112	106	92	6	5	1 680 000	3 500 000	171 000	355 000	530	750
	520	87	82	71	5	4	1 210 000	2 550 000	124 000	260 000	560	750
420	540	87	82	71	5	4	1 250 000	2 700 000	128 000	276 000	530	710
	600	125	118	100	6	5	1 960 000	4 050 000	200 000	415 000	480	670
440	560	87	82	72	5	4	1 300 000	2 810 000	132 000	287 000	500	670
	620	125	118	100	6	5	2 000 000	4 200 000	204 000	430 000	450	630
440	650	130	122	104	6	6	2 230 000	4 600 000	227 000	470 000	430	600

Bearing Numbers	ISO355 Dimension Series approx.	Abutment and Fillet Dimensions (mm)						Cone Cup	Eff. Load Centers (mm) a	Constant e	Axial Load Factors		Mass (kg) approx.		
		d _a min.	d _b max.	D _a max.	D _b min.	S _a min.	S _b min.				Y ₁	Y ₀			
HR 32952 J HR 32052 XJ 30252	3EC	278	278	348	333	347	11	15.5	2.5	2	69.8	0.41	1.5	0.81	18.6
	4FC	287	287	382	357	383	14	22	4	3	86.3	0.43	1.4	0.76	38.5
	—	293	316	458	421	447	12	22	5	4	94.6	0.44	1.4	0.74	60.7
32252 30352 32352	—	293	305	458	394	446	14	31	5	4	116.0	0.45	1.3	0.73	103
	—	293	336	512	460	487	16	28	5	5	101.6	0.36	1.7	0.92	114
	—	293	328	512	441	495	13	40	5	5	130.5	0.37	1.6	0.88	188
HR 32956 J HR 32056 XJ 30256	4EC	298	297	368	352	368	12	15.5	2.5	2	75.3	0.43	1.4	0.76	20
	4FC	307	305	402	374	402	14	22	4	3	91.6	0.46	1.3	0.72	40.6
	—	313	339	478	436	462	12	22	5	4	98.5	0.44	1.4	0.74	66.3
32256 32356	—	313	325	478	412	467	14	31	5	4	123.1	0.47	1.3	0.70	109
	—	319	353	552	475	532	14	42	5	5	139.6	0.37	1.6	0.89	224
	32960	—	321	326	406	386	405	13	14	3	2.5	79.3	0.37	1.6	0.88
HR 32960 J HR 32060 XJ	3FD	321	324	406	387	405	13	19	3	2.5	79.9	0.39	1.5	0.84	31.4
	4GD	327	330	442	408	439	15	26	4	3	98.4	0.43	1.4	0.76	56.6
	30260	—	333	355	518	470	499	14	25	5	4	105.1	0.44	1.4	0.74
32260	—	333	352	518	458	514	15	34	5	4	131.7	0.46	1.3	0.72	132
32964 HR 32964 J HR 32064 XJ	—	341	345	426	404	425	13	13	3	2.5	84.3	0.39	1.5	0.84	32
	3FD	341	344	426	406	426	13	19	3	2.5	85.0	0.42	1.4	0.79	33.3
	4GD	347	350	462	430	461	15	26	4	3	104.5	0.46	1.3	0.72	60
30264 32264 32364	—	353	381	558	503	533	14	29	5	4	113.7	0.44	1.4	0.74	99.3
	—	353	383	558	487	550	15	34	5	4	141.7	0.46	1.3	0.72	175
	—	383	412	634	547	616	14	42	6	6	157.5	0.37	1.6	0.88	343
32968 HR 32968 J 32068	—	361	364	446	426	446	13	13	3	2.5	89.2	0.41	1.5	0.80	33.6
	4FD	361	362	446	427	446	13	19	3	2.5	91.0	0.44	1.4	0.75	34.3
	—	373	386	498	464	496	3.5	22	5	4	104.5	0.37	1.6	0.89	83.7
32972 HR 32972 J 32072	—	381	386	466	445	465	14	14	3	2.5	91.4	0.40	1.5	0.82	35.8
	4FD	381	381	466	445	466	13	19	3	2.5	96.8	0.46	1.3	0.72	36.1
	—	393	402	518	480	514	5.5	22	5	4	108.6	0.38	1.6	0.86	86.5
32976	—	407	406	502	478	501	16	16	4	3	95.2	0.39	1.6	0.86	49.5
32980 32080	—	427	428	522	499	524	16	16	4	3	100.8	0.40	1.5	0.82	52.7
	—	433	443	578	533	565	5	25	5	4	115.3	0.36	1.7	0.92	116
32984 32084	—	447	448	542	521	544	3.5	15	4	3	106.1	0.41	1.5	0.81	54.8
	—	453	463	598	552	586	6.5	25	5	4	120.0	0.37	1.6	0.88	121
32088	—	473	487	622	582	616	5	26	5	5	126.3	0.36	1.7	0.92	136

SINGLE-ROW TAPERED ROLLER BEARINGS (INCH DESIGN)

Bore Diameter 12.000 – 22.225 mm

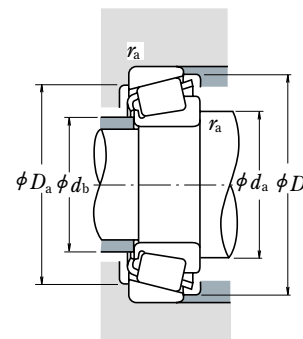
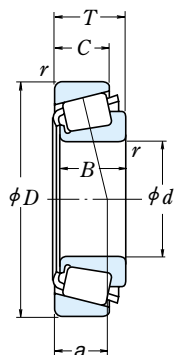

Dynamic Equivalent Load

$$P = X F_r + Y F_a$$

$F_a / F_r \leq e$		$F_a / F_r > e$	
X	Y	X	Y
1	0	0.4	Y_1

Static Equivalent Load

$P_0 = 0.5 F_r + Y_0 F_a$
 When $F_r > 0.5 F_r + Y_0 F_a$, use $P_0 = F_r$
 The values of e , Y_1 , and Y_0 are given in the table below.

Boundary Dimensions (mm)						Basic Load Ratings (N)				Limiting Speeds (min ⁻¹)		
d	D	T	B	C	Cone r min.	C_r	C_{0r}	C_r	C_{0r}	Grease	Oil	
12.000	31.991	10.008	10.785	7.938	0.8	1 3	10 300	8 900	1 050	905	13 000	18 000
12.700	34.988	10.998	10.988	8.730	1.3	1 3	11 700	10 900	1 200	1 110	12 000	16 000
15.000	34.988	10.998	10.988	8.730	0.8	1 3	11 700	10 900	1 200	1 110	12 000	16 000
15.875	34.988	10.998	10.998	8.712	1.3	1 3	13 800	13 400	1 410	1 360	11 000	15 000
	39.992	12.014	11.153	9.525	1.3	1 3	14 900	15 700	1 520	1 600	9 500	13 000
	41.275	14.288	14.681	11.112	1.3	2 0	21 300	19 900	2 170	2 030	10 000	13 000
	42.862	14.288	14.288	9.525	1.5	1 5	17 300	17 200	1 770	1 750	8 500	12 000
	42.862	16.670	16.670	13.495	1.5	1 5	26 900	26 300	2 750	2 680	9 500	13 000
	44.450	15.494	14.381	11.430	1.5	1 5	23 800	23 900	2 430	2 440	8 500	11 000
	49.225	19.845	21.539	14.288	0.8	1 3	37 500	37 000	3 800	3 800	8 500	11 000
16.000	47.000	21.000	21.000	16.000	1.0	2 0	35 000	36 500	3 600	3 750	9 000	12 000
16.993	39.992	12.014	11.153	9.525	0.8	1 3	14 900	15 700	1 520	1 600	9 500	13 000
17.455	36.525	11.112	11.112	7.938	1.5	1 5	11 600	11 000	1 190	1 120	10 000	14 000
17.462	39.878	13.843	14.605	10.668	1.3	1 3	22 500	22 500	2 290	2 290	10 000	13 000
	47.000	14.381	14.381	11.112	0.8	1 3	23 800	23 900	2 430	2 440	8 500	11 000
19.050	39.992	12.014	11.153	9.525	1.0	1 3	14 900	15 700	1 520	1 600	9 500	13 000
	45.237	15.494	16.637	12.065	1.3	1 3	28 500	28 900	2 910	2 950	9 000	12 000
	47.000	14.381	14.381	11.112	1.3	1 3	23 800	23 900	2 430	2 440	8 500	11 000
	49.225	18.034	19.050	14.288	1.3	1 3	37 500	37 000	3 800	3 800	8 500	11 000
	49.225	19.845	21.539	14.288	1.2	1 3	37 500	37 000	3 800	3 800	8 500	11 000
	49.225	21.209	19.050	17.462	1.3	1 5	37 500	37 000	3 800	3 800	8 500	11 000
	49.225	23.020	21.539	17.462	C1.5	3.5	37 500	37 000	3 800	3 800	8 500	11 000
	53.975	22.225	21.839	15.875	1.5	2 3	40 500	39 500	4 150	4 000	7 500	10 000
19.990	47.000	14.381	14.381	11.112	1.5	1 3	23 800	23 900	2 430	2 440	8 500	11 000
20.000	51.994	15.011	14.260	12.700	1.5	1 3	26 000	27 900	2 650	2 840	7 500	10 000
20.625	49.225	23.020	21.539	17.462	1.5	1 5	37 500	37 000	3 800	3 800	8 500	11 000
20.638	49.225	19.845	19.845	15.875	1.5	1 5	36 000	37 000	3 650	3 750	8 000	11 000
21.430	50.005	17.526	18.288	13.970	1.3	1 3	38 500	40 000	3 950	4 100	8 000	11 000
22.000	45.237	15.494	16.637	12.065	1.3	1 3	29 200	33 500	2 980	3 400	8 500	11 000
	45.975	15.494	16.637	12.065	1.3	1 3	29 200	33 500	2 980	3 400	8 500	11 000
22.225	50.005	13.495	14.260	9.525	1.3	1 0	26 000	27 900	2 650	2 840	7 500	10 000
	50.005	17.526	18.288	13.970	1.3	1 3	38 500	40 000	3 950	4 100	8 000	11 000
	52.388	19.368	20.168	14.288	1.5	1 5	40 500	43 000	4 100	4 400	7 500	10 000
	53.975	19.368	20.168	14.288	1.5	1 5	40 500	43 000	4 100	4 400	7 500	10 000
	56.896	19.368	19.837	15.875	1.3	1 3	38 000	40 500	3 900	4 150	7 100	9 500
	57.150	22.225	22.225	17.462	0.8	1 5	48 000	50 000	4 850	5 100	7 100	9 500

Bearing Numbers		Abutment and Fillet Dimensions (mm)				Eff. Load Centers (mm)	Constant	Axial Load Factors		Mass (kg)			
CONE	CUP	d_a	d_b	D_a	D_b	Cone r_a max.	a	e	Y_1	Y_0	approx. CONE CUP		
*A 2047	A 2126	16.5	15.5	26	29	0.8	1.3	6.8	0.41	1.5	0.81	0.023	0.017
A 4050	A 4138	18.5	17	29	32	1.3	1.3	8.2	0.45	1.3	0.73	0.033	0.022
*A 4059	A 4138	19.5	19	29	32	0.8	1.3	8.2	0.45	1.3	0.73	0.029	0.022
L 21549	L 21511	21.5	19.5	29	32.5	1.3	1.3	7.7	0.32	1.9	1.0	0.031	0.018
A 6062	A 6157	22	20.5	34	37	1.3	1.3	10.3	0.53	1.1	0.63	0.044	0.031
03062	03162	21.5	20	34	37.5	1.3	2	9.1	0.31	1.9	1.1	0.061	0.035
11590	11520	24.5	22.5	34.5	39.5	1.5	1.5	13.0	0.70	0.85	0.47	0.061	0.040
17580	17520	23	21	36.5	39	1.5	1.5	10.6	0.33	1.8	1.0	0.075	0.048
05062	05175	23.5	21	38	42	1.5	1.5	11.2	0.36	1.7	0.93	0.081	0.039
09062	09195	22	21.5	42	44.5	0.8	1.3	10.7	0.27	2.3	1.2	0.139	0.065
*HM 81649	**HM 81610	27.5	23	37.5	43	1	2	14.9	0.55	1.1	0.60	0.115	0.082
A 6067	A 6157	22	21	34	37	0.8	1.3	10.3	0.53	1.1	0.63	0.042	0.031
A 5069	A 5144	23.5	21.5	30	33.5	1.5	1.5	8.9	0.49	1.2	0.68	0.030	0.020
† LM 11749	† LM 11710	23	21.5	34	37	1.3	1.3	8.7	0.29	2.1	1.2	0.055	0.028
05068	05185	23	22.5	40.5	42.5	0.8	1.3	10.1	0.36	1.7	0.93	0.082	0.047
A 6075	A 6157	24	23	34	37	1	1.3	10.3	0.53	1.1	0.63	0.037	0.031
† LM 11949	† LM 11910	25	23.5	39.5	41.5	1.3	1.3	9.5	0.30	2.0	1.1	0.081	0.044
05075	05185	25	23.5	40.5	42.5	1.3	1.3	10.1	0.36	1.7	0.93	0.077	0.047
09067	09195	25.5	24	42	44.5	1.3	1.3	10.7	0.27	2.3	1.2	0.115	0.065
09078	09195	25.5	24	42	44.5	1.2	1.3	10.7	0.27	2.3	1.2	0.124	0.065
09067	09196	25.5	24	41.5	44.5	1.3	1.5	13.8	0.27	2.3	1.2	0.115	0.085
09074	09194	26	24	39	44.5	1.5	3.5	13.8	0.27	2.3	1.2	0.124	0.082
21075	21212	31.5	26	43	50	1.5	2.3	16.3	0.59	1.0	0.56	0.156	0.097
05079	05185	26.5	24	40.5	42.5	1.5	1.3	10.1	0.36	1.7	0.93	0.073	0.047
07079	07204	27.5	27	45	48	1.5	1.3	12.1	0.40	1.5	0.82	0.105	0.061
09081	09196	27.5	25.5	41.5	44.5	1.5	1.5	13.8	0.27	2.3	1.2	0.115	0.085
12580	12520	28.5	26	42.5	45.5	1.5	1.5	12.9	0.32	1.9	1.0	0.114	0.067
† M 12649	† M 12610	27.5	25.5	44	46	1.3	1.3	10.9	0.28	2.2	1.2	0.115	0.059
*† LM 12749	† LM 12710	27.5	26	39.5	42.5	1.3	1.3	10.0	0.31	2.0	1.1	0.078	0.038
*† LM 12749	† LM 12711	27.5	26	40	42.5	1.3	1.3	10.0	0.31	2.0	1.1	0.078	0.043
07087	07196	28.5	27	44.5	47	1.3	1	10.6	0.40	1.5	0.82	0.097	0.035
† M 12648	† M 12610	28.5	26.5	44	46	1.3	1.3	10.9	0.28	2.2	1.2	0.111	0.059
1380	1328	29.5	27	45	48.5	1.5	1.5	11.3	0.29	2.1	1.1	0.137	0.067
1380	1329	29.5	27	46	49	1.5	1.5	11.3	0.29	2.1	1.1	0.137	0.082
1755	1729	29	27.5	49	51	1.3	1.3	12.2	0.31	2.0	1.1	0.152	0.102
1280	1220	29.5	29	49	52	0.8	1.5	15.1	0.35	1.7	0.95	0.183	0.106

- Notes**
- * The maximum bore diameter is listed and its tolerance is negative (See Table 8.4.1 on Page A68).
 - ** The maximum outside diameter is listed and its tolerance is negative (See Table 8.4.2 on Pages A68 and A69).
 - † The tolerances for the bore diameter and overall bearing width differ from the standard (See Table 5 on Page B114).
 - * † The tolerance for the bore diameter is 0 to -20 μm, and for overall bearing width is +356 to 0 μm.

SINGLE-ROW TAPERED ROLLER BEARINGS (INCH DESIGN)

Bore Diameter 22.606 – 28.575 mm

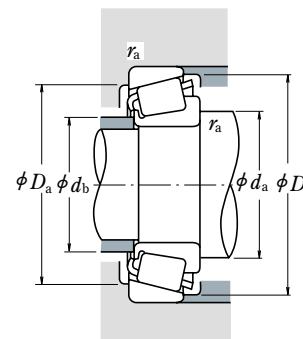
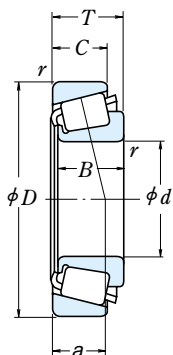

Dynamic Equivalent Load

$$P = XF_r + YF_a$$

$F_a/F_r \leq e$		$F_a/F_r > e$	
X	Y	X	Y
1	0	0.4	Y_1

Static Equivalent Load

$P_0 = 0.5F_r + Y_0F_a$
 When $F_r > 0.5F_r + Y_0F_a$, use $P_0 = F_r$
 The values of e , Y_1 , and Y_0 are given in the table below.

Boundary Dimensions (mm)					Basic Load Ratings (N)				Limiting Speeds (min ⁻¹)	
d	D	T	B	C	C _r	C _{0r}	C _r	C _{0r}	Grease	Oil
22.606	47.000	15.500	15.500	12.000	26 300	30 000	2 680	3 100	8 000	11 000
23.812	50.292	14.224	14.732	10.668	27 600	32 000	2 820	3 250	7 100	10 000
	56.896	19.368	19.837	15.875	38 000	40 500	3 900	4 150	7 100	9 500
24.000	55.000	25.000	25.000	21.000	49 500	55 000	5 050	5 650	7 100	9 500
24.981	51.994	15.011	14.260	12.700	26 000	27 900	2 650	2 840	7 500	10 000
	52.001	15.011	14.260	12.700	26 000	27 900	2 650	2 840	7 500	10 000
	62.000	16.002	16.566	14.288	37 000	39 500	3 750	4 000	6 300	8 500
25.000	50.005	13.495	14.260	9.525	26 000	27 900	2 650	2 840	7 500	10 000
	51.994	15.011	14.260	12.700	26 000	27 900	2 650	2 840	7 500	10 000
25.400	50.005	13.495	14.260	9.525	26 000	27 900	2 650	2 840	7 500	10 000
	50.005	13.495	14.260	9.525	26 000	27 900	2 650	2 840	7 500	10 000
	50.292	14.224	14.732	10.668	27 600	32 000	2 820	3 250	7 100	10 000
	57.150	17.462	17.462	13.495	39 500	45 500	4 050	4 650	6 700	9 000
	57.150	19.431	19.431	14.732	42 500	49 000	4 300	5 000	6 700	9 000
	59.530	23.368	23.114	18.288	50 000	58 000	5 100	5 900	6 300	9 000
	62.000	19.050	20.638	14.288	46 000	53 000	4 700	5 400	6 000	8 000
	63.500	20.638	20.638	15.875	46 000	53 000	4 700	5 400	6 000	8 000
	64.292	21.433	21.433	16.670	51 000	64 500	5 200	6 600	5 600	8 000
	65.088	22.225	21.463	15.875	45 000	47 500	4 600	4 850	5 600	8 000
	68.262	22.225	22.225	17.462	55 000	64 000	5 600	6 550	5 600	7 500
	72.233	25.400	25.400	19.842	63 500	83 500	6 500	8 500	5 000	7 100
	72.626	24.608	24.257	17.462	60 000	58 000	6 100	5 900	5 600	7 500
26.988	50.292	14.224	14.732	10.668	27 600	32 000	2 820	3 250	7 100	10 000
	57.150	19.845	19.355	15.875	40 000	44 500	4 100	4 500	6 700	9 000
	60.325	19.842	17.462	15.875	39 500	45 500	4 050	4 650	6 700	9 000
	62.000	19.050	20.638	14.288	46 000	53 000	4 700	5 400	6 000	8 000
28.575	57.150	19.845	19.355	15.875	40 000	44 500	4 100	4 500	6 700	9 000
	59.131	15.875	16.764	11.811	34 500	41 500	3 550	4 200	6 300	8 500
	62.000	19.050	20.638	14.288	46 000	53 000	4 700	5 400	6 000	8 000
	62.000	19.050	20.638	14.288	46 000	53 000	4 700	5 400	6 000	8 000
	64.292	21.433	21.433	16.670	51 000	64 500	5 200	6 600	5 600	8 000
	68.262	22.225	22.225	17.462	55 000	64 000	5 600	6 550	5 600	7 500
	72.626	24.608	24.257	17.462	60 000	58 000	6 100	5 900	5 600	7 500
	72.626	24.608	24.257	17.462	60 000	58 000	6 100	5 900	5 600	7 500
	73.025	22.225	22.225	17.462	54 500	64 500	5 550	6 600	5 300	7 100

Bearing Numbers		Abutment and Fillet Dimensions (mm)				Eff. Load Centers (mm)		Constant	Axial Load Factors		Mass (kg)	
CONE	CUP	d _a	d _b	D _a	D _b	a	e	e	Y ₁	Y ₀	CONE approx.	CUP approx.
LM 72849	LM 72810	29	27	40.5	44.5	1.5	1	12.2	0.47	1.3	0.086	0.046
† L 44640	† L 44610	30.5	28.5	44.5	47	1.5	1.3	10.9	0.37	1.6	0.097	0.039
	1779	29.5	28.5	49	51	0.8	1.3	12.2	0.31	2.0	0.143	0.102
▲ JHM 33449	▲ JHM 33410	35	30	47	52	2	2	15.8	0.35	1.7	0.093	0.107
07098	07204	31	29	45	48	1.5	1.3	12.1	0.40	1.5	0.085	0.061
07098	07205	31	29	44.5	48	1.5	2	12.1	0.40	1.5	0.085	0.061
17098	17244	33	30.5	54	57	1.5	1.5	12.8	0.38	1.6	0.086	0.091
07097	07196	31	29	44.5	47	1.5	1	10.6	0.40	1.5	0.085	0.035
07097	07204	31	29	45	48	1.5	1.3	12.1	0.40	1.5	0.085	0.061
07100 SA	07196	35	29.5	44.5	47	3.3	1	10.6	0.40	1.5	0.082	0.035
07100	07196	30.5	29.5	44.5	47	1	1	10.6	0.40	1.5	0.082	0.035
† L 44643	† L 44610	31.5	29.5	44.5	47	1.3	1.3	10.9	0.37	1.6	0.090	0.039
15578	15520	32.5	30.5	51	53	1.3	1.5	12.4	0.35	1.7	0.095	0.070
M 84548	M 84510	36	33	48.5	54	1.5	1.5	16.1	0.55	1.1	0.160	0.089
M 84249	M 84210	36	32.5	49.5	56	0.8	1.5	18.3	0.55	1.1	0.160	0.13
15101	15245	32.5	31.5	55	58	0.8	1.3	13.3	0.35	1.7	0.094	0.081
15100	15250 X	38	31.5	55	59	3.5	1.5	14.9	0.35	1.7	0.094	0.113
M 86643	M 86610	38	36.5	54	61	1.5	1.5	17.7	0.55	1.1	0.246	0.128
23100	23256	39	34.5	53	61	1.5	1.5	20.0	0.73	0.82	0.214	0.142
02473	02420	34.5	33.5	59	63	0.8	1.5	16.9	0.42	1.4	0.28	0.152
HM 88630	HM 88610	39.5	39.5	60	69	0.8	2.3	20.7	0.55	1.1	0.398	0.188
41100	41286	41	36.5	61	68	2.3	1.5	20.7	0.60	1.0	0.55	0.32
† L 44649	† L 44610	37.5	31	44.5	47	3.5	1.3	10.9	0.37	1.6	0.081	0.039
1997 X	1922	37.5	31.5	51	53.5	3.3	1.5	13.9	0.33	1.8	1.0	0.152
15580	15523	38.5	32	51	54	3.5	1.5	14.7	0.35	1.7	0.95	0.141
15106	15245	33.5	33	55	58	0.8	1.3	13.3	0.35	1.7	0.94	0.211
1988	1922	39.5	33.5	51	53.5	3.5	1.5	13.9	0.33	1.8	1.0	0.141
† LM 67043	† LM 67010	40	33.5	52	56	3.5	1.3	12.6	0.41	1.5	0.80	0.147
15112	15245	40	34	55	58	3.5	1.3	13.3	0.35	1.7	0.94	0.199
15113	15245	34.5	34	55	58	0.8	1.3	13.3	0.35	1.7	0.94	0.20
M 86647	M 86610	40	38	54	61	1.5	1.5	17.7	0.55	1.1	0.60	0.223
02474	02420	36.5	36	59	63	0.8	1.5	16.9	0.42	1.4	0.79	0.257
41125	41286	48	36.5	61	68	4.8	1.5	20.7	0.60	1.0	0.55	0.292
41126	41286	41.5	36.5	61	68	1.5	1.5	20.7	0.60	1.0	0.55	0.295
02872	02820	37.5	37	62	68	0.8	3.3	18.3	0.45	1.3	0.73	0.321

Notes † The tolerances for the bore diameter and overall bearing width differ from the standard (See Table 5 on Page B114).
 ▲ The tolerances are listed in Tables 2, 3 and 4 on Pages B113 and B114.

SINGLE-ROW TAPERED ROLLER BEARINGS (INCH DESIGN)

Bore Diameter 29.000 – 32.000 mm

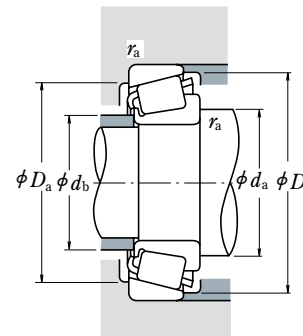
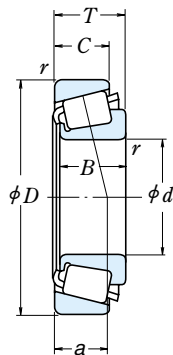

Dynamic Equivalent Load

$$P = X F_r + Y F_a$$

$F_a / F_r \leq e$		$F_a / F_r > e$	
X	Y	X	Y
1	0	0.4	Y_1

Static Equivalent Load

$P_0 = 0.5 F_r + Y_0 F_a$
 When $F_r > 0.5 F_r + Y_0 F_a$, use $P_0 = F_r$
 The values of e , Y_1 , and Y_0 are given in the table below.

d	Boundary Dimensions (mm)					Cone r min.	Cup	Basic Load Ratings (N)				Limiting Speeds (min ⁻¹)	
	D	T	B	C	C _r			C _{0r}	C _r	C _{0r}	Grease	Oil	
29.000	50.292	14.224	14.732	10.668	3.5	1.3	26 800	34 000	2 730	3 500	7 100	9 500	
29.367	66.421	23.812	25.433	19.050	3.5	1.3	65 000	73 000	6 600	7 450	6 000	8 000	
30.000	62.000	16.002	16.566	14.288	1.5	1.5	37 000	39 500	3 750	4 000	6 300	8 500	
	62.000	19.050	20.638	14.288	1.3	1.3	46 000	53 000	4 700	5 400	6 000	8 000	
	63.500	20.638	20.638	15.875	1.3	1.3	46 000	53 000	4 700	5 400	6 000	8 000	
	72.000	19.000	18.923	15.875	1.5	1.5	52 000	56 000	5 300	5 700	5 600	7 500	
30.112	62.000	19.050	20.638	14.288	0.8	1.3	46 000	53 000	4 700	5 400	6 000	8 000	
30.162	58.738	14.684	15.080	10.716	3.5	1.0	28 800	33 500	2 940	3 450	6 000	8 000	
	64.292	21.433	21.433	16.670	1.5	1.5	51 000	64 500	5 200	6 600	5 600	8 000	
	68.262	22.225	22.225	17.462	2.3	1.5	55 500	70 500	5 650	7 200	5 300	7 500	
	69.850	23.812	25.357	19.050	2.3	1.3	71 000	84 000	7 200	8 550	5 600	7 500	
	69.850	23.812	25.357	19.050	0.8	1.3	71 000	84 000	7 200	8 550	5 600	7 500	
	76.200	24.608	24.074	16.670	1.5	C3.3	67 500	69 500	6 850	7 100	5 000	6 700	
30.213	62.000	19.050	20.638	14.288	3.5	1.3	46 000	53 000	4 700	5 400	6 000	8 000	
	62.000	19.050	20.638	14.288	0.8	1.3	46 000	53 000	4 700	5 400	6 000	8 000	
	62.000	19.050	20.638	14.288	1.5	1.3	46 000	53 000	4 700	5 400	6 000	8 000	
30.955	64.292	21.433	21.433	16.670	1.5	1.5	51 000	64 500	5 200	6 600	5 600	8 000	
31.750	58.738	14.684	15.080	10.716	1.0	1.0	28 800	33 500	2 940	3 450	6 000	8 000	
	59.131	15.875	16.764	11.811	spec.	1.3	34 500	41 500	3 550	4 200	6 300	8 500	
	62.000	18.161	19.050	14.288	spec.	1.3	46 000	53 000	4 700	5 400	6 000	8 000	
	62.000	19.050	20.638	14.288	0.8	1.3	46 000	53 000	4 700	5 400	6 000	8 000	
	62.000	19.050	20.638	14.288	3.5	1.3	46 000	53 000	4 700	5 400	6 000	8 000	
	63.500	20.638	20.638	15.875	0.8	1.3	46 000	53 000	4 700	5 400	6 000	8 000	
	68.262	22.225	22.225	17.462	3.5	1.5	55 000	64 000	5 600	6 550	5 600	7 500	
	68.262	22.225	22.225	17.462	1.5	1.5	55 500	70 500	5 650	7 200	5 300	7 500	
	69.012	19.845	19.583	15.875	3.5	1.3	47 000	56 000	4 800	5 700	5 600	7 500	
	69.012	26.982	26.721	15.875	4.3	3.3	47 000	56 000	4 800	5 700	5 600	7 500	
	69.850	23.812	25.357	19.050	0.8	1.3	71 000	84 000	7 200	8 550	5 600	7 500	
	69.850	23.812	25.357	19.050	3.5	1.3	71 000	84 000	7 200	8 550	5 600	7 500	
	72.626	30.162	29.997	23.812	0.8	3.3	79 500	90 000	8 100	9 200	5 300	7 500	
	73.025	29.370	27.783	23.020	1.3	3.3	74 000	100 000	7 550	10 200	5 000	7 100	
	80.000	21.000	22.403	17.826	0.8	1.3	68 500	75 500	6 950	7 700	4 500	6 300	
32.000	72.233	25.400	25.400	19.842	3.3	2.3	63 500	83 500	6 500	8 500	5 000	7 100	

Bearing Numbers		Abutment and Fillet Dimensions (mm)					Eff. Load Centers (mm) a	Constant e	Axial Load Factors		Mass (kg)		
CONE	CUP	d _a	d _b	D _a	D _b	Cone r _a max.			Y ₁	Y ₀	approx. CONE	CUP	
† L 45449	† L 45410	39.5	33	44.5	48	3.5	1.3	10.8	0.37	1.6	0.89	0.079	0.036
2690	2631	41	35	58	60	3.5	1.3	14.3	0.25	2.4	1.3	0.242	0.165
* 17118	17244	37	34.5	54	57	1.5	1.5	12.8	0.38	1.6	0.86	0.136	0.091
* 15117	15245	36.5	35	55	58	1.3	1.3	13.3	0.35	1.7	0.94	0.189	0.081
* 15117	15250	36.5	35	56	59	1.3	1.3	14.9	0.35	1.7	0.94	0.189	0.113
* 26118	26283	38	36	62	65	1.5	1.5	14.8	0.36	1.7	0.92	0.225	0.163
15116	15245	36	35.5	55	58	0.8	1.3	13.3	0.35	1.7	0.94	0.189	0.081
08118	08231	41.5	35	52	55	3.5	1	13.3	0.47	1.3	0.70	0.12	0.057
M 86649	M 86610	41	38	54	61	1.5	1.5	17.7	0.55	1.1	0.60	0.211	0.128
M 88043	M 88010	43.5	39.5	58	65	2.3	1.5	19.1	0.55	1.1	0.60	0.263	0.146
2558	2523	40	36.5	61	64	2.3	1.3	14.5	0.27	2.2	1.2	0.297	0.169
2559	2523	37	36.5	61	64	0.8	1.3	14.5	0.27	2.2	1.2	0.298	0.169
43118	43300	45	42	64	73	1.5	3.3	22.9	0.67	0.90	0.49	0.383	0.146
15118	15245	41.5	35.5	55	58	3.5	1.3	13.3	0.35	1.7	0.94	0.186	0.081
15120	15245	36	35.5	55	58	0.8	1.3	13.3	0.35	1.7	0.94	0.188	0.081
15119	15245	37.5	35.5	55	58	1.5	1.3	13.3	0.35	1.7	0.94	0.188	0.081
M 86648 A	M 86610	42	38	54	61	1.5	1.5	17.7	0.55	1.1	0.60	0.205	0.128
08125	08231	37.5	36	52	55	1	1	13.3	0.47	1.3	0.70	0.113	0.057
† LM 67048	† LM 67010	42.5	36	52	56	3.5	1.3	12.6	0.41	1.5	0.80	0.127	0.062
15123	15245	42.5	36.5	55	58	3.5	1.3	13.3	0.35	1.7	0.94	0.165	0.081
15126	15245	37	36.5	55	58	0.8	1.3	13.3	0.35	1.7	0.94	0.176	0.081
15125	15245	42.5	36.5	55	58	3.5	1.3	13.3	0.35	1.7	0.94	0.174	0.081
15126	15250	37	36.5	56	59	0.8	1.3	14.9	0.35	1.7	0.94	0.176	0.113
02475	02420	44.5	38.5	59	63	3.5	1.5	16.9	0.42	1.4	0.79	0.229	0.152
M 88046	M 88010	43	40.5	58	65	1.5	1.5	19.1	0.55	1.1	0.60	0.25	0.146
14125 A	14276	44	37.5	60	63	3.5	1.3	15.3	0.38	1.6	0.86	0.219	0.135
14123 A	14274	41.5	37.5	59	63	4.3	3.3	15.1	0.38	1.6	0.87	0.289	0.132
2580	2523	38.5	37.5	61	64	0.8	1.3	14.5	0.27	2.2	1.2	0.282	0.169
2582	2523	44	37.5	61	64	3.5	1.3	14.5	0.27	2.2	1.2	0.28	0.169
3188	3120	39.5	39.5	61	67	0.8	3.3	19.6	0.33	1.8	0.99	0.368	0.225
HM 88542	HM 88510	45.5	42.5	59	70	1.3	3.3	23.5	0.55	1.1	0.60	0.379	0.242
346	332	40	39.5	73	75	0.8	1.3	14.6	0.27	2.2	1.2	0.419	0.146
*HM 88638	HM 88610	48.5	42.5	60	69	3.3	2.3	20.7	0.55	1.1	0.60	0.337	0.188

Notes * The maximum bore diameter is listed and its tolerance is negative (See Table 8.4.1 on Page A68).
 † The tolerances for the bore diameter and overall bearing width differ from the standard (See Table 5 on Page B114).

SINGLE-ROW TAPERED ROLLER BEARINGS (INCH DESIGN)

Bore Diameter 33.338 – 35.000 mm

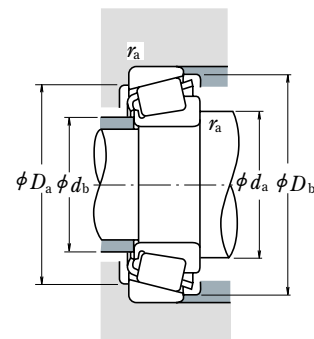
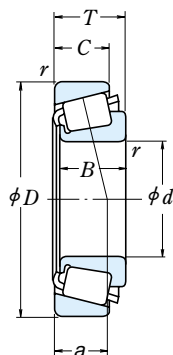

Dynamic Equivalent Load

$$P = XF_r + YF_a$$

$F_a/F_r \leq e$		$F_a/F_r > e$	
X	Y	X	Y
1	0	0.4	Y_1

Static Equivalent Load

$P_0 = 0.5F_r + Y_0F_a$
 When $F_r > 0.5F_r + Y_0F_a$, use $P_0 = F_r$
 The values of e , Y_1 , and Y_0 are given in the table below.

d	Boundary Dimensions (mm)					Cone r min.	Cup	Basic Load Ratings (N)				Limiting Speeds (min ⁻¹)	
	D	T	B	C	C _r			C _{0r}	C _r	C _{0r}	Grease	Oil	
33.338	66.675	20.638	20.638	15.875	3.5	1.5	46 000	53 500	4 650	5 450	5 600	7 500	
	68.262	22.225	22.225	17.462	0.8	1.5	55 500	70 500	5 650	7 200	5 300	7 500	
	69.012	19.845	19.583	15.875	3.5	3.3	47 000	56 000	4 800	5 700	5 600	7 500	
	69.012	19.845	19.583	15.875	0.8	1.3	47 000	56 000	4 800	5 700	5 600	7 500	
	69.850	23.812	25.357	19.050	3.5	1.3	71 000	84 000	7 200	8 550	5 600	7 500	
	72.000	19.000	18.923	15.875	3.5	1.5	52 000	56 000	5 300	5 700	5 600	7 500	
	72.626	30.162	29.997	23.812	0.8	3.3	79 500	90 000	8 100	9 200	5 300	7 500	
	73.025	29.370	27.783	23.020	0.8	3.3	74 000	100 000	7 550	10 200	5 000	7 100	
	76.200	29.370	28.575	23.020	3.8	0.8	78 500	106 000	8 000	10 800	4 800	6 700	
	76.200	29.370	28.575	23.020	0.8	3.3	78 500	106 000	8 000	10 800	4 800	6 700	
	79.375	25.400	24.074	17.462	3.5	1.5	67 500	69 500	6 850	7 100	5 000	6 700	
	34.925	65.088	18.034	18.288	13.970	spec.	1.3	47 500	57 500	4 850	5 900	5 600	7 500
65.088		20.320	18.288	16.256	spec.	1.3	47 500	57 500	4 850	5 900	5 600	7 500	
66.675		20.638	20.638	16.670	3.5	2.3	53 000	62 500	5 400	6 400	5 600	7 500	
69.012		19.845	19.583	15.875	3.5	1.3	47 000	56 000	4 800	5 700	5 600	7 500	
69.012		19.845	19.583	15.875	1.5	1.3	47 000	56 000	4 800	5 700	5 600	7 500	
72.233		25.400	25.400	19.842	2.3	2.3	63 500	83 500	6 500	8 500	5 000	7 100	
73.025		22.225	22.225	17.462	0.8	3.3	54 500	64 500	5 550	6 600	5 300	7 100	
73.025		22.225	23.812	17.462	3.5	3.3	63 500	77 000	6 500	7 850	5 300	7 100	
73.025		23.812	24.608	19.050	1.5	0.8	71 000	86 000	7 250	8 750	5 300	7 100	
73.025		23.812	24.608	19.050	3.5	2.3	71 000	86 000	7 250	8 750	5 300	7 100	
76.200		29.370	28.575	23.020	0.8	0.8	78 500	106 000	8 000	10 800	4 800	6 700	
76.200		29.370	28.575	23.020	3.5	0.8	78 500	106 000	8 000	10 800	4 800	6 700	
34.976	68.262	15.875	16.520	11.908	1.5	1.5	45 000	53 500	4 600	5 450	5 300	7 100	
	72.085	22.385	19.583	18.415	1.3	2.3	47 000	56 000	4 800	5 700	5 600	7 500	
	80.000	21.006	20.940	15.875	1.5	1.5	56 500	64 500	5 750	6 600	5 000	6 700	
	35.000	59.131	15.875	16.764	11.938	spec.	1.3	35 000	47 000	3 550	4 750	6 000	8 000
		59.975	15.875	16.764	11.938	spec.	1.3	35 000	47 000	3 550	4 750	6 000	8 000
		62.000	16.700	17.000	13.600	spec.	1.0	38 000	50 000	3 900	5 100	5 600	8 000
		62.000	16.700	17.000	13.600	spec.	1.5	38 000	50 000	3 900	5 100	5 600	8 000
		65.987	20.638	20.638	16.670	3.5	2.3	53 000	62 500	5 400	6 400	5 600	7 500
		73.025	26.988	26.975	22.225	3.5	0.8	75 500	88 500	7 650	9 050	5 300	7 500

Bearing Numbers		Abutment and Fillet Dimensions (mm)				Cone r _a max.	Cup	Eff. Load Centers (mm) a	Constant e	Axial Load Factors		Mass (kg)	
CONE	CUP	d _a	d _b	D _a	D _b					Y ₁	Y ₀	approx. CONE	CUP
1680	1620	44.5	38.5	58	61	3.5	1.5	15.2	0.37	1.6	0.89	0.196	0.121
M 88048	M 88010	42.5	41	58	65	0.8	1.5	19.0	0.55	1.1	0.60	0.236	0.146
14130	14274	45	38.5	59	63	3.5	3.3	15.3	0.38	1.6	0.86	0.207	0.132
14131	14276	39.5	38.5	60	63	0.8	1.3	15.3	0.38	1.6	0.86	0.209	0.135
2585	2523	45	39	61	64	3.5	1.3	14.5	0.27	2.2	1.2	0.263	0.169
26131	26283	44.5	38.5	62	65	3.5	1.5	14.7	0.36	1.7	0.92	0.20	0.163
3197	3120	41.5	40.5	61	67	0.8	3.3	19.6	0.33	1.8	0.99	0.348	0.225
HM 88547	HM 88510	45.5	42.5	59	70	0.8	3.3	23.5	0.55	1.1	0.60	0.362	0.242
HM 89444	HM 89411	53	44.5	65	73	3.8	0.8	23.6	0.55	1.1	0.60	0.419	0.261
HM 89443	HM 89410	46.5	44.5	62	73	0.8	3.3	23.6	0.55	1.1	0.60	0.421	0.257
43131	43312	51	42	67	74	3.5	1.5	23.7	0.67	0.90	0.49	0.348	0.22
† LM 48548	† LM 48510	46	40	58	61	3.5	1.3	14.1	0.38	1.6	0.88	0.172	0.087
† LM 48548	† LM 48511	46	40	58	61	3.5	1.3	16.4	0.38	1.6	0.88	0.172	0.108
M 38549	M 38510	46.5	40	58	62	3.5	2.3	15.2	0.35	1.7	0.94	0.194	0.112
14138 A	14276	46	40	60	63	3.5	1.3	15.3	0.38	1.6	0.86	0.194	0.135
14137 A	14276	42	40	60	63	1.5	1.3	15.1	0.38	1.6	0.86	0.196	0.135
HM 88649	HM 88610	48.5	42.5	60	69	2.3	2.3	20.7	0.55	1.1	0.60	0.307	0.188
02878	02820	42.5	42	62	68	0.8	3.3	18.3	0.45	1.3	0.73	0.266	0.16
2877	2820	47	41.5	63	68	3.5	3.3	16.1	0.37	1.6	0.90	0.291	0.15
25877	25821	43	40.5	65	68	1.5	0.8	15.7	0.29	2.1	1.1	0.306	0.167
25878	25820	47	40.5	64	68	3.5	2.3	15.7	0.29	2.1	1.1	0.304	0.165
HM 89446 A	HM 89411	47.5	44.5	65	73	0.8	0.8	23.6	0.55	1.1	0.60	0.403	0.261
HM 89446	HM 89411	53	44.5	65	73	3.5	0.8	23.6	0.55	1.1	0.60	0.40	0.261
HM 89446	HM 89410	53	44.5	62	73	3.5	3.3	23.6	0.55	1.1	0.60	0.40	0.257
31594	31520	46	43.5	64	72	1.5	3.3	21.6	0.40	1.5	0.82	0.404	0.235
3478	3420	50	43.5	67	74	3.5	3.3	20.0	0.37	1.6	0.90	0.448	0.259
19138	19268	42.5	40.5	61	65	1.5	1.5	14.5	0.44	1.4	0.74	0.196	0.073
14139	14283	41.5	40	60	65	1.3	2.3	17.7	0.38	1.6	0.87	0.198	0.21
28138	28315	43.5	41	69	73	1.5	1.5	16.0	0.40	1.5	0.82	0.308	0.199
* † L 68149	† L 68110	45.5	39	52	56	3.5	1.3	13.2	0.42	1.4	0.79	0.117	0.056
* † L 68149	† L 68111	45.5	39	53	56	3.5	1.3	13.2	0.42	1.4	0.79	0.117	0.064
* LM 78349	** LM 78310	46	40	55	59	3.5	1	14.4	0.44	1.4	0.74	0.137	0.074
* LM 78349	** LM 78310 A	46	40	54	59	3.5	1.5	14.4	0.44	1.4	0.74	0.138	0.073
M 38547	M 38511	46	39.5	59	61	3.5	2.3	15.2	0.35	1.7	0.94	0.193	0.103
23691	23621	49	42	63	68	3.5	0.8	18.1	0.37	1.6	0.89	0.309	0.212

- Notes**
- * The maximum bore diameter is listed and its tolerance is negative (See Table 8.4.1 on Page A68).
 - ** The maximum outside diameter is listed and its tolerance is negative (See Table 8.4.2 on Pages A68 and A69).
 - † The tolerances for the bore diameter and overall bearing width differ from the standard (See Table 5 on Page B114).
 - * † The tolerance for the bore diameter is 0 to -20 μm, and for overall bearing width is +356 to 0 μm.

SINGLE-ROW TAPERED ROLLER BEARINGS (INCH DESIGN)

Bore Diameter 35.717 – 41.275 mm

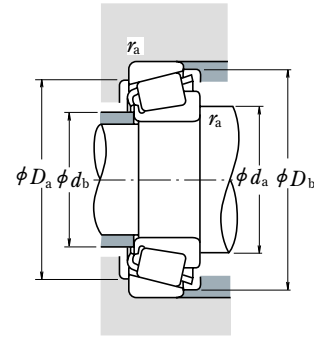
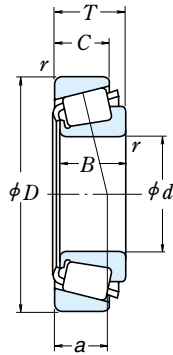

Dynamic Equivalent Load

$$P = XF_r + YF_a$$

$F_a/F_r \leq e$		$F_a/F_r > e$	
X	Y	X	Y
1	0	0.4	Y_1

Static Equivalent Load

$P_0 = 0.5F_r + Y_0F_a$
 When $F_r > 0.5F_r + Y_0F_a$, use $P_0 = F_r$
 The values of e , Y_1 , and Y_0 are given in the table below.

d	Boundary Dimensions (mm)					Cone r min.	Cup r max.	Basic Load Ratings (N) (kgf)				Limiting Speeds (min ⁻¹)	
	D	T	B	C	C_r			C_{0r}	C_r	C_{0r}	Grease	Oil	
35.717	72.233	25.400	25.400	19.842	3.5	2.3	63 500	83 500	6 500	8 500	5 000	7 100	
36.487	73.025	23.812	24.608	19.050	1.5	0.8	71 000	86 000	7 250	8 750	5 300	7 100	
36.512	76.200	29.370	28.575	23.020	3.5	3.3	78 500	106 000	8 000	10 800	4 800	6 700	
	79.375	29.370	29.771	23.812	0.8	3.3	88 000	106 000	8 950	10 800	4 800	6 700	
	88.501	25.400	23.698	17.462	2.3	1.5	73 000	81 000	7 450	8 250	4 000	5 600	
	93.662	31.750	31.750	26.195	1.5	3.3	110 000	142 000	11 200	14 400	4 000	5 600	
38.000	63.000	17.000	17.000	13.500	spec.	1.3	38 500	52 000	3 900	5 300	5 600	7 500	
38.100	63.500	12.700	11.908	9.525	1.5	0.8	24 100	30 500	2 460	3 100	5 300	7 100	
	65.088	18.034	18.288	13.970	2.3	1.3	42 500	55 000	4 300	5 650	5 300	7 500	
	65.088	18.034	18.288	13.970	spec.	1.3	42 500	55 000	4 300	5 650	5 300	7 500	
	65.088	19.812	18.288	15.748	2.3	1.3	42 500	55 000	4 300	5 650	5 300	7 500	
	68.262	15.875	16.520	11.908	1.5	1.5	45 000	53 500	4 600	5 450	5 300	7 100	
	69.012	19.050	19.050	15.083	2.0	2.3	49 000	61 000	4 950	6 250	5 300	7 100	
	69.012	19.050	19.050	15.083	3.5	0.8	49 000	61 000	4 950	6 250	5 300	7 100	
	72.238	20.638	20.638	15.875	3.5	1.3	48 500	59 500	4 950	6 050	5 300	7 100	
	73.025	23.812	25.654	19.050	3.5	0.8	73 500	91 000	7 500	9 300	5 000	6 700	
	76.200	23.812	25.654	19.050	3.5	3.3	73 500	91 000	7 500	9 300	5 000	6 700	
	76.200	23.812	25.654	19.050	3.5	0.8	73 500	91 000	7 500	9 300	5 000	6 700	
	79.375	29.370	29.771	23.812	3.5	3.3	88 000	106 000	8 950	10 800	4 800	6 700	
	80.035	24.608	23.698	18.512	0.8	1.5	69 000	84 500	7 000	8 600	4 500	6 300	
	82.550	29.370	28.575	23.020	0.8	3.3	87 000	117 000	8 850	11 900	4 500	6 000	
	88.501	25.400	23.698	17.462	2.3	1.5	73 000	81 000	7 450	8 250	4 000	5 600	
	88.501	26.988	29.083	22.225	3.5	1.5	96 500	109 000	9 800	11 100	4 500	6 000	
	95.250	30.958	28.301	20.638	1.5	0.8	87 500	97 000	8 950	9 850	3 600	5 300	
39.688	73.025	25.654	22.098	21.336	0.8	2.3	62 500	80 000	6 400	8 150	5 000	6 700	
	76.200	23.812	25.654	19.050	3.5	3.3	73 500	91 000	7 500	9 300	5 000	6 700	
	80.167	29.370	30.391	23.812	0.8	3.3	92 500	108 000	9 450	11 000	4 800	6 300	
40.000	80.000	21.000	22.403	17.826	3.5	1.3	68 500	75 500	6 950	7 700	4 500	6 300	
	80.000	21.000	22.403	17.826	0.8	1.3	68 500	75 500	6 950	7 700	4 500	6 300	
	88.501	25.400	23.698	17.462	2.3	1.5	73 000	81 000	7 450	8 250	4 000	5 600	
41.000	68.000	17.500	18.000	13.500	spec.	1.5	43 500	58 000	4 450	5 950	5 300	7 100	
41.275	73.025	16.667	17.462	12.700	3.5	1.5	44 500	54 000	4 550	5 500	4 800	6 700	
	73.431	19.558	19.812	14.732	3.5	0.8	54 500	67 000	5 550	6 850	4 800	6 700	
	73.431	21.430	19.812	16.604	3.5	0.8	54 500	67 000	5 550	6 850	4 800	6 700	

Bearing Numbers		Abutment and Fillet Dimensions (mm)				Cone r _a max.	Cup r _a max.	Eff. Load Centers (mm) a	Constant e	Axial Load Factors		Mass (kg)	
CONE	CUP	d _a	d _b	D _a	D _b					Y ₁	Y ₀	approx. CONE	CUP
HM 88648	HM 88610	52	43	60	69	3.5	2.3	20.7	0.55	1.1	0.60	0.298	0.188
25880	25821	44	42	65	68	1.5	0.8	15.7	0.29	2.1	1.1	0.291	0.167
HM 89449	HM 89410	54	44.5	62	73	3.5	3.3	23.6	0.55	1.1	0.60	0.38	0.257
3479	3420	45.5	44.5	67	74	0.8	3.3	20.0	0.37	1.6	0.90	0.429	0.259
44143	44348	54	50	75	84	2.3	1.5	27.9	0.78	0.77	0.42	0.502	0.245
46143	46368	48.5	46.5	79	87	1.5	3.3	24.0	0.40	1.5	0.82	0.765	0.405
▲ JL 69349	▲ JL 69310	49	42.5	56	60	3.5	1.3	14.6	0.42	1.4	0.79	0.132	0.071
13889	13830	45	42.5	59	60	1.5	0.8	11.9	0.35	1.7	0.95	0.109	0.046
LM 29749	LM 29710	46	42.5	59	62	2.3	1.3	13.7	0.33	1.8	0.99	0.16	0.079
LM 29748	LM 29710	49	42.5	59	62	3.5	1.3	13.7	0.33	1.8	0.99	0.158	0.079
LM 29749	LM 29711	46	42.5	58	62	2.3	1.3	15.5	0.33	1.8	0.99	0.16	0.094
19150	19268	45	43	61	65	1.5	1.5	14.5	0.44	1.4	0.74	0.173	0.073
13687	13621	46.5	43	61	65	2	2.3	15.8	0.40	1.5	0.82	0.193	0.104
13685	13620	49.5	43	62	65	3.5	0.8	15.8	0.40	1.5	0.82	0.191	0.105
16150	16284	49.5	43	63	67	3.5	1.3	16.0	0.40	1.5	0.82	0.212	0.146
2788	2735 X	50	43.5	66	69	3.5	0.8	15.9	0.30	2.0	1.1	0.312	0.135
2788	2720	50	43.5	66	70	3.5	3.3	15.9	0.30	2.0	1.1	0.312	0.187
2788	2729	50	43.5	68	70	3.5	0.8	15.9	0.30	2.0	1.1	0.312	0.191
3490	3420	52	45.5	67	74	3.5	3.3	20.0	0.37	1.6	0.90	0.404	0.259
27880	27820	48	47	68	75	0.8	1.5	21.5	0.56	1.1	0.59	0.362	0.209
HM 801346	HM 801310	51	49	68	78	0.8	3.3	24.2	0.55	1.1	0.60	0.483	0.282
44150	44348	55	51	75	84	2.3	1.5	27.9	0.78	0.77	0.42	0.484	0.245
418	414	51	44.5	77	80	3.5	1.5	17.1	0.26	2.3	1.3	0.50	0.329
53150	53375	55	53	81	89	1.5	0.8	30.7	0.74	0.81	0.45	0.665	0.365
M 201047	M 201011	45.5	48	64	69	0.8	2.3	19.7	0.33	1.8	0.99	0.266	0.169
2789	2720	52	45	66	70	3.5	3.3	15.9	0.30	2.0	1.1	0.292	0.187
3386	3320	46.5	45.5	70	75	0.8	3.3	18.4	0.27	2.2	1.2	0.442	0.217
344	332	52	45.5	73	75	3.5	1.3	14.5	0.27	2.2	1.2	0.338	0.146
344 A	332	46	45.5	73	75	0.8	1.3	14.5	0.27	2.2	1.2	0.339	0.146
44157	44348	56	51	75	84	2.3	1.5	27.9	0.78	0.77	0.42	0.463	0.245
* LM 300849	** LM 300811	52	45	61	65	3.5	1.5	13.9	0.35	1.7	0.95	0.16	0.082
18590	18520	53	46	66	69	3.5	1.5	14.0	0.35	1.7	0.94	0.199	0.086
LM 501349	LM 501310	53	46.5	67	70	3.5	0.8	16.3	0.40	1.5	0.83	0.226	0.108
LM 501349	LM 501314	53	46.5	66	70	3.5	0.8	18.2	0.40	1.5	0.83	0.226	0.129

- Notes
- * The maximum bore diameter is listed and its tolerance is negative (See Table 8.4.1 on Page A68).
 - ** The maximum outside diameter is listed and its tolerance is negative (See Table 8.4.2 on Pages A68 and A69).
 - ▲ The tolerances are listed in Tables 2, 3 and 4 on Pages B113 and B114.

SINGLE-ROW TAPERED ROLLER BEARINGS (INCH DESIGN)

Bore Diameter 41.275 – 44.450 mm

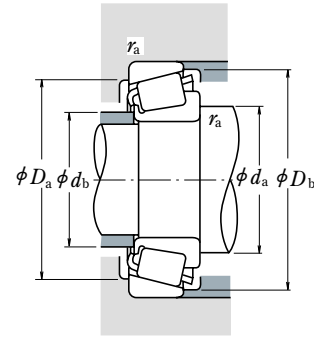
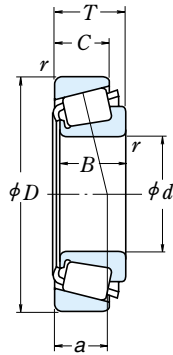

Dynamic Equivalent Load

$$P = XF_r + YF_a$$

$F_a/F_r \leq e$		$F_a/F_r > e$	
X	Y	X	Y
1	0	0.4	Y_1

Static Equivalent Load

$P_0 = 0.5F_r + Y_0F_a$
 When $F_r > 0.5F_r + Y_0F_a$, use $P_0 = F_r$
 The values of e , Y_1 , and Y_0 are given in the table below.

Boundary Dimensions (mm)					Basic Load Ratings (N)				Limiting Speeds (min ⁻¹)				
d	D	T	B	C	Cone r min.	Cup r max.	C_r	C_{0r}	C_r	C_{0r}	Grease	Oil	
41.275	76.200	18.009	17.384	14.288	1.5	1.5	42 500	51 000	4 350	5 200	4 500	6 300	
	76.200	22.225	23.020	17.462	3.5	0.8	66 000	82 000	6 700	8 400	4 800	6 700	
	76.200	25.400	23.020	20.638	3.5	2.3	66 000	82 000	6 700	8 400	4 800	6 700	
	79.375	23.812	25.400	19.050	3.5	0.8	77 000	98 500	7 850	10 000	4 800	6 300	
	80.000	21.000	22.403	17.826	0.8	1.3	68 500	75 500	6 950	7 700	4 500	6 300	
	80.000	21.000	22.403	17.826	3.5	1.3	68 500	75 500	6 950	7 700	4 500	6 300	
	80.167	25.400	25.400	20.638	3.5	3.3	77 000	98 500	7 850	10 000	4 800	6 300	
	82.550	26.543	25.654	20.193	3.5	3.3	78 500	102 000	8 000	10 400	4 300	6 000	
	85.725	30.162	30.162	23.812	3.5	3.3	91 000	115 000	9 300	11 700	4 300	6 000	
	87.312	30.162	30.886	23.812	0.8	3.3	96 000	120 000	9 800	12 200	4 300	6 000	
42.862	88.501	25.400	23.698	17.462	2.3	1.5	73 000	81 000	7 450	8 250	4 000	5 600	
	88.900	30.162	29.370	23.020	3.5	3.3	96 500	129 000	9 800	13 200	4 000	5 600	
	88.900	30.162	29.370	23.020	0.8	3.3	96 500	129 000	9 800	13 200	4 000	5 600	
	90.488	39.688	40.386	33.338	3.5	3.3	139 000	180 000	14 200	18 400	4 300	5 600	
	93.662	31.750	31.750	26.195	0.8	3.3	110 000	142 000	11 200	14 400	4 000	5 600	
	95.250	30.162	29.370	23.020	3.5	3.3	106 000	143 000	10 800	14 500	3 800	5 300	
	98.425	30.958	28.301	20.638	1.5	0.8	87 500	97 000	8 950	9 850	3 600	5 300	
	76.992	17.462	17.145	11.908	1.5	1.5	44 000	54 000	4 450	5 500	4 500	6 000	
	82.550	19.842	19.837	15.080	2.3	1.5	58 500	69 000	5 950	7 050	4 500	6 300	
	82.931	23.812	25.400	19.050	2.3	0.8	76 500	99 000	7 800	10 100	4 500	6 000	
42.875	82.931	26.988	25.400	22.225	2.3	2.3	76 500	99 000	7 800	10 100	4 500	6 000	
	76.200	25.400	25.400	20.638	3.5	1.5	77 000	98 500	7 850	10 000	4 800	6 300	
	80.000	21.000	22.403	17.826	3.5	1.3	68 500	75 500	6 950	7 700	4 500	6 300	
	82.931	26.988	25.400	22.225	3.5	2.3	76 500	99 000	7 800	10 100	4 500	6 000	
	83.058	23.812	25.400	19.050	3.5	3.3	76 500	99 000	7 800	10 100	4 500	6 000	
	74.988	19.368	19.837	14.288	1.5	1.3	52 500	68 000	5 350	6 900	4 800	6 300	
	43.000	80.962	19.050	17.462	14.288	0.3	1.5	45 000	57 000	4 600	5 800	4 300	6 000
		82.931	23.812	25.400	19.050	3.5	0.8	76 500	99 000	7 800	10 100	4 500	6 000
		83.058	23.812	25.400	19.050	3.5	3.3	76 500	99 000	7 800	10 100	4 500	6 000
		87.312	30.162	30.886	23.812	3.5	3.3	96 000	120 000	9 800	12 200	4 300	6 000
88.900		30.162	29.370	23.020	3.5	3.3	96 500	129 000	9 800	13 200	4 000	5 600	
93.264		30.162	30.302	23.812	3.5	3.2	103 000	136 000	10 500	13 900	3 800	5 300	
93.662		31.750	31.750	25.400	0.8	3.3	120 000	147 000	12 200	15 000	4 000	5 600	
93.662		31.750	31.750	25.400	3.5	3.3	120 000	147 000	12 200	15 000	4 000	5 600	
93.662		31.750	31.750	26.195	3.5	3.3	110 000	142 000	11 200	14 400	4 000	5 600	
95.250		27.783	29.901	22.225	3.5	2.3	106 000	126 000	10 800	12 900	4 300	5 600	

Bearing Numbers		Abutment and Fillet Dimensions (mm)				Eff. Load Centers (mm)	Constant	Axial Load Factors		Mass (kg)		
CONE	CUP	d_a	d_b	D_a	D_b	a	e	Y_1	Y_0	approx. CONE	CUP	
11162	11300	49	46.5	67	71	1.5	1.5	17.4	0.49	1.2	0.68	
	24780	24720	53	47.5	68	72	3.5	0.8	17.0	0.39	1.5	0.84
	24780	24721	54	47	66	72	3.5	2.3	20.2	0.39	1.5	0.84
	26882	26822	54	47	71	74	3.5	0.8	16.4	0.32	1.9	1.0
	336	332	47	46	73	75	0.8	1.3	14.5	0.27	2.2	1.2
	342	332	53	46	73	75	3.5	1.3	14.5	0.27	2.2	1.2
	26882	26820	54	47	69	74	3.5	3.3	18.0	0.32	1.9	1.0
	M 802048	M 802011	57	51	70	79	3.5	3.3	22.9	0.55	1.1	0.60
	3877	3820	57	50	73	81	3.5	3.3	21.8	0.40	1.5	0.82
	3576	3525	49	48	75	81	0.8	3.3	19.5	0.31	2.0	1.1
HM 803146	HM 803110	57	51	75	84	2.3	1.5	28.0	0.78	0.77	0.42	
	4388	4335	57	51	77	85	3.5	3.3	24.6	0.28	2.1	1.2
	46162	46368	60	53	74	85	3.5	3.3	25.6	0.55	1.1	0.60
	HM 803145	HM 803110	54	53	74	85	0.8	3.3	25.6	0.55	1.1	0.60
	4388	4335	57	51	77	85	3.5	3.3	24.6	0.28	2.1	1.2
	46162	46368	60	53	79	87	0.8	3.3	24.0	0.40	1.5	0.82
	HM 804840	HM 804810	61	54	81	91	3.5	3.3	26.1	0.55	1.1	0.60
	53162	53387	57	53	82	91	1.5	0.8	30.7	0.74	0.81	0.45
	12168	12303	51	48.5	68	73	1.5	1.5	17.7	0.51	1.2	0.65
	22168	22325	52	48.5	73	76	2.3	1.5	17.6	0.43	1.4	0.77
25578	25520	53	49.5	74	77	2.3	0.8	17.6	0.33	1.8	0.99	
	25578	25523	53	49.5	72	77	2.3	2.3	20.8	0.33	1.8	0.99
	26884	26823	55	48.5	69	73	3.5	1.5	18.0	0.32	1.9	1.0
	342 S	332	54	47.5	73	75	3.5	1.3	14.5	0.27	2.2	1.2
	25577	25523	55	49	72	77	3.5	2.3	20.8	0.33	1.8	0.99
	25577	25521	55	49	72	77	3.5	3.3	17.6	0.33	1.8	0.99
	* 16986	16929	51	48.5	67	71	1.5	1.3	17.2	0.44	1.4	0.74
	13175	13318	50	50	72	76	0.3	1.5	20.1	0.53	1.1	0.63
	25580	25520	57	50	74	77	3.5	0.8	17.6	0.33	1.8	0.99
	25580	25521	56	51	72	78	3.5	3.3	17.6	0.33	1.8	0.99
HM 803149	HM 803110	57	51	75	81	3.5	3.3	19.5	0.31	2.0	1.1	
	3782	3720	62	53	74	85	3.5	3.3	25.6	0.55	1.1	0.60
	49176	49368	54	53	82	87	0.8	3.3	21.6	0.36	1.7	0.92
	49175	49368	59	53	82	87	3.5	3.3	21.6	0.36	1.7	0.92
	46176	46368	60	54	79	87	3.5	3.3	24.0	0.40	1.5	0.82
	438	432	57	51	83	87	3.5	2.3	18.6	0.28	2.1	1.2

Note * The maximum bore diameter is listed and its tolerance is negative (See Table 8.4.1 on Page A68).

SINGLE-ROW TAPERED ROLLER BEARINGS (INCH DESIGN)

Bore Diameter 48.412 – 52.388 mm

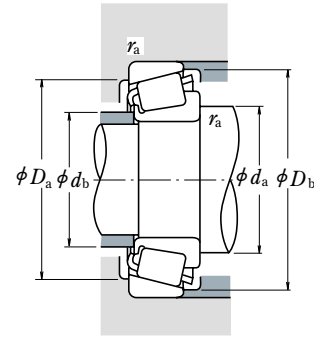
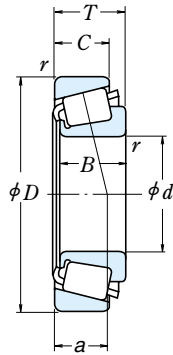

Dynamic Equivalent Load

$$P = XF_r + YF_a$$

$F_a/F_r \leq e$		$F_a/F_r > e$	
X	Y	X	Y
1	0	0.4	Y_1

Static Equivalent Load

$P_0 = 0.5F_r + Y_0F_a$
 When $F_r > 0.5F_r + Y_0F_a$, use $P_0 = F_r$
 The values of e , Y_1 , and Y_0 are given in the table below.

Boundary Dimensions (mm)						Basic Load Ratings (N) (kgf)				Limiting Speeds (min ⁻¹)	
d	D	T	B	C	Cone r Cup min.	C _r	C _{0r}	C _r	C _{0r}	Grease	Oil
48.412	95.250	30.162	29.370	23.020	3.5 3.3	106 000	143 000	10 800	14 500	3 800	5 300
	95.250	30.162	29.370	23.020	2.3 3.3	106 000	143 000	10 800	14 500	3 800	5 300
49.212	104.775	36.512	36.512	28.575	3.5 0.8	139 000	192 000	14 200	19 600	3 400	4 800
	114.300	44.450	44.450	36.068	3.5 3.3	196 000	243 000	20 000	24 800	3 400	4 800
50.000	82.000	21.500	21.500	17.000	3.0 0.5	71 000	96 000	7 250	9 800	4 300	5 600
	82.550	21.590	22.225	16.510	0.5 1.3	71 000	96 000	7 250	9 800	4 300	5 600
	88.900	20.638	22.225	16.513	2.3 1.3	73 000	85 000	7 450	8 650	4 000	5 600
	90.000	28.000	28.000	23.000	3.0 2.5	104 000	136 000	10 600	13 900	4 000	5 600
50.800	105.000	37.000	36.000	29.000	3.0 2.5	139 000	192 000	14 200	19 600	3 400	4 800
	80.962	18.258	18.258	14.288	1.5 1.5	53 000	81 000	5 400	8 250	4 300	5 600
	82.550	23.622	22.225	18.542	3.5 0.8	71 000	96 000	7 250	9 800	4 300	5 600
	82.931	21.590	22.225	16.510	3.5 1.3	71 000	96 000	7 250	9 800	4 300	5 600
	85.000	17.462	17.462	13.495	3.5 1.5	48 500	63 000	4 950	6 450	4 300	5 600
	85.725	19.050	18.263	12.700	1.5 1.5	42 500	54 000	4 350	5 500	4 000	5 300
	88.900	20.638	22.225	16.513	3.5 1.3	73 000	85 000	7 450	8 650	4 000	5 600
	88.900	20.638	22.225	16.513	1.5 1.3	73 000	85 000	7 450	8 650	4 000	5 600
	92.075	24.608	25.400	19.845	3.5 0.8	84 500	117 000	8 600	11 900	4 000	5 300
	93.264	30.162	30.302	23.812	0.8 0.8	103 000	136 000	10 500	13 900	3 800	5 300
	93.264	30.162	30.302	23.812	3.5 0.8	103 000	136 000	10 500	13 900	3 800	5 300
	95.250	27.783	28.575	22.225	3.5 2.3	110 000	144 000	11 200	14 700	3 800	5 300
	101.600	31.750	31.750	25.400	3.5 3.3	118 000	150 000	12 100	15 200	3 600	5 000
	101.600	34.925	36.068	26.988	0.8 3.3	137 000	169 000	14 000	17 200	3 800	5 000
	101.600	34.925	36.068	26.988	3.5 3.3	137 000	169 000	14 000	17 200	3 800	5 000
	104.775	36.512	36.512	28.575	3.5 0.8	139 000	192 000	14 200	19 600	3 400	4 800
	104.775	36.512	36.512	28.575	3.5 3.3	139 000	192 000	14 200	19 600	3 400	4 800
	108.966	34.925	36.512	26.988	3.5 3.3	145 000	181 000	14 700	18 500	3 600	4 800
	111.125	30.162	26.909	20.638	3.5 3.3	113 000	152 000	11 500	15 400	3 000	4 300
	111.125	30.162	26.909	20.638	3.5 3.3	92 500	110 000	9 450	11 200	3 200	4 300
	123.825	36.512	32.791	25.400	3.5 3.3	162 000	199 000	16 500	20 300	2 800	4 000
	123.825	36.512	32.791	25.400	3.5 3.3	143 000	160 000	14 600	16 400	3 000	4 000
127.000	44.450	44.450	34.925	3.5 3.3	199 000	258 000	20 200	26 300	3 000	4 000	
127.000	50.800	52.388	41.275	3.5 3.3	236 000	300 000	24 000	31 000	3 200	4 300	
52.388	92.075	24.608	25.400	19.845	3.5 0.8	84 500	117 000	8 600	11 900	4 000	5 300
	100.000	25.000	22.225	21.824	2.3 2.0	77 000	93 000	7 900	9 500	3 800	5 300
	111.125	30.162	26.909	20.638	3.5 3.3	92 500	110 000	9 450	11 200	3 200	4 300

Bearing Numbers		Abutment and Fillet Dimensions (mm)				Eff. Load Centers (mm)		Constant	Axial Load Factors		Mass (kg)	
CONE	CUP	d _a	d _b	D _a	D _b	a	e	Y ₁	Y ₀	approx. CONE CUP		
HM 804849	HM 804810	66	57	81	91	3.5 3.3	26.1	0.55	1.1	0.60	0.61	0.354
HM 804848	HM 804810	63	57	81	91	2.3 3.3	26.1	0.55	1.1	0.60	0.614	0.354
HM 807044	HM 807011	69	63	91	100	3.5 0.8	29.7	0.49	1.2	0.68	1.03	0.508
HH 506348	HH 506310	71	61	97	107	3.5 3.3	30.8	0.40	1.5	0.82	1.43	0.837
▲ JLM 104948	▲ JLM 104910	60	55	76	78	3 0.5	16.1	0.31	2.0	1.1	0.306	0.129
* LM 104947 A	LM 104911	55	55	75	78	0.5 1.3	15.7	0.31	2.0	1.1	0.316	0.133
366	362 A	59	55	81	84	2.3 1.3	16.6	0.32	1.9	1.0	0.351	0.166
▲ JM 205149	▲ JM 205110	62	57	80	85	3 2.5	19.9	0.33	1.8	1.0	0.507	0.246
▲ JHM 807045	▲ JHM 807012	69	63	90	100	3 2.5	29.7	0.49	1.2	0.68	1.01	0.523
L 305649	L 305610	58	56	73	77	1.5 1.5	15.7	0.36	1.7	0.93	0.239	0.119
LM 104949	LM 104911 A	62	55	75	78	3.5 0.8	17.8	0.31	2.0	1.1	0.303	0.156
LM 104949	LM 104912	62	55	75	78	3.5 1.3	15.7	0.31	2.0	1.1	0.301	0.14
18790	18720	62	56	77	80	3.5 1.5	16.7	0.41	1.5	0.81	0.239	0.136
18200	18337	59	56	76	81	1.5 1.5	21.0	0.57	1.1	0.58	0.268	0.136
368 A	362 A	62	56	81	84	3.5 1.3	16.6	0.32	1.9	1.0	0.338	0.166
368	362 A	58	56	81	84	1.5 1.3	16.6	0.32	1.9	1.0	0.341	0.166
28580	28521	63	57	83	87	3.5 0.8	20.0	0.38	1.6	0.87	0.46	0.247
3775	3730	58	58	84	88	0.8 0.8	22.4	0.34	1.8	0.97	0.568	0.297
3780	3730	64	58	84	88	3.5 0.8	22.4	0.34	1.8	0.97	0.564	0.297
33889	33821	64	58	85	90	3.5 2.3	19.8	0.33	1.8	1.0	0.601	0.267
49585	49520	66	59	88	96	3.5 3.3	23.4	0.40	1.5	0.82	0.744	0.389
529	522	59	58	89	95	0.8 3.3	22.1	0.29	2.1	1.2	0.822	0.416
529 X	522	65	58	89	95	3.5 3.3	22.1	0.29	2.1	1.2	0.819	0.416
HM 807046	HM 807011	70	63	91	100	3.5 0.8	29.7	0.49	1.2	0.68	0.992	0.508
HM 807046	HM 807010	70	63	89	100	3.5 3.3	29.7	0.49	1.2	0.68	0.993	0.502
59200	59429	68	61	93	101	3.5 3.3	25.4	0.40	1.5	0.82	0.943	0.594
55200 C	55437	71	65	92	105	3.5 3.3	37.6	0.88	0.68	0.37	0.845	0.514
55200	55437	71	64	92	105	3.5 3.3	37.3	0.88	0.68	0.37	0.767	0.514
72200 C	72487	77	67	102	116	3.5 3.3	38.0	0.74	0.81	0.45	1.33	0.79
72200	72487	74	66	102	116	3.5 3.3	37.0	0.74	0.81	0.45	1.22	0.79
65200	65500	75	69	107	119	3.5 3.3	35.0	0.49	1.2	0.68	1.86	1.03
6279	6220	71	65	108	117	3.5 3.3	30.7	0.30	2.0	1.1	2.08	1.22
28584	28521	65	58	83	87	3.5 0.8	20.0	0.38	1.6	0.87	0.435	0.247
377	372	62	58	86	90	2.3 2	21.4	0.34	1.8	0.97	0.392	0.435
55206	55437	72	64	92	105	3.5 3.3	37.3	0.88	0.68	0.37	0.737	0.514

Notes * The maximum bore diameter is listed and its tolerance is negative (See Table 8.4.1 on Page A68).

▲ The tolerances are listed in Tables 2, 3 and 4 on Pages B113 and B114.

SINGLE-ROW TAPERED ROLLER BEARINGS (INCH DESIGN)

Bore Diameter 60.000 – 64.963 mm

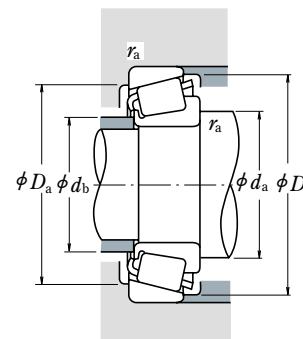
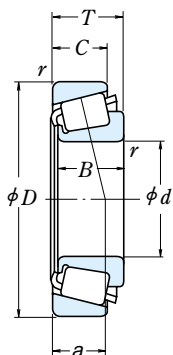

Dynamic Equivalent Load

$$P = X F_r + Y F_a$$

$F_a / F_r \leq e$		$F_a / F_r > e$	
X	Y	X	Y
1	0	0.4	Y_1

Static Equivalent Load

$P_0 = 0.5 F_r + Y_0 F_a$
 When $F_r > 0.5 F_r + Y_0 F_a$, use $P_0 = F_r$
 The values of e , Y_1 , and Y_0 are given in the table below.

Boundary Dimensions (mm)						Basic Load Ratings (N) (kgf)				Limiting Speeds (min ⁻¹)		
d	D	T	B	C	Cone r	Cup	C _r	C _{0r}	C _r	C _{0r}	Grease	Oil
60.000	95.000	24.000	24.000	19.000	5.0	2.5	86 500	125 000	8 800	12 800	3 600	5 000
	104.775	21.433	22.000	15.875	2.3	2.0	83 500	107 000	8 500	10 900	3 400	4 500
	110.000	22.000	21.996	18.824	0.8	1.3	85 500	113 000	8 750	11 500	3 200	4 300
	122.238	33.338	31.750	23.812	3.5	3.3	135 000	156 000	13 800	15 900	3 000	4 000
60.325	100.000	25.400	25.400	19.845	3.5	3.3	91 000	135 000	9 250	13 700	3 400	4 800
	101.600	25.400	25.400	19.845	3.5	3.3	91 000	135 000	9 250	13 700	3 400	4 800
	122.238	38.100	36.678	30.162	2.3	3.3	161 000	221 000	16 400	22 500	3 000	4 000
	122.238	38.100	38.354	29.718	8.0	1.5	188 000	245 000	19 200	25 000	3 000	4 000
	122.238	43.658	43.764	36.512	0.8	3.3	198 000	292 000	20 200	29 700	3 000	4 000
	127.000	44.450	44.450	34.925	3.5	3.3	199 000	258 000	20 200	26 300	3 000	4 000
	130.175	41.275	41.275	31.750	3.5	3.3	195 000	263 000	19 800	26 800	2 800	3 800
	135.755	53.975	56.007	44.450	3.5	3.3	264 000	355 000	27 000	36 000	2 800	3 800
61.912	136.525	46.038	46.038	36.512	3.5	3.3	233 000	370 000	23 800	37 500	2 600	3 400
	146.050	41.275	39.688	25.400	3.5	3.3	193 000	225 000	19 700	22 900	2 400	3 400
	152.400	47.625	46.038	31.750	3.5	3.3	237 000	267 000	24 200	27 300	2 400	3 400
63.500	94.458	19.050	19.050	15.083	1.5	1.5	59 000	100 000	6 050	10 200	3 600	4 800
	104.775	21.433	22.000	15.875	2.0	2.0	83 500	107 000	8 500	10 900	3 400	4 500
	107.950	25.400	25.400	19.050	1.5	3.3	90 000	138 000	9 150	14 100	3 200	4 300
	110.000	22.000	21.996	18.824	3.5	1.3	85 500	113 000	8 750	11 500	3 200	4 300
	110.000	22.000	21.996	18.824	1.5	1.3	85 500	113 000	8 750	11 500	3 200	4 300
	112.712	30.162	30.048	23.812	3.5	3.2	120 000	173 000	12 200	17 700	3 200	4 300
	112.712	30.162	30.162	23.812	3.5	3.3	142 000	202 000	14 500	20 600	3 200	4 300
	112.712	33.338	30.048	26.988	3.5	3.3	120 000	173 000	12 200	17 700	3 200	4 300
	122.238	38.100	38.354	29.718	7.0	3.3	188 000	245 000	19 200	25 000	3 000	4 000
	122.238	38.100	38.354	29.718	7.0	1.5	188 000	245 000	19 200	25 000	3 000	4 000
	122.238	38.100	38.354	29.718	3.5	1.5	188 000	245 000	19 200	25 000	3 000	4 000
	122.238	43.658	43.764	36.512	3.5	3.3	198 000	292 000	20 200	29 700	3 000	4 000
	123.825	38.100	36.678	30.162	3.5	3.3	161 000	221 000	16 400	22 500	3 000	4 000
	127.000	36.512	36.170	28.575	3.5	3.3	166 000	234 000	16 900	23 900	2 800	3 800
	130.175	41.275	41.275	31.750	3.5	3.3	195 000	263 000	19 800	26 800	2 800	3 800
	136.525	36.512	33.236	23.520	2.3	3.3	152 000	183 000	15 500	18 700	2 600	3 600
	136.525	41.275	41.275	31.750	3.5	3.3	195 000	263 000	19 800	26 800	2 800	3 800
	140.030	36.512	33.236	23.520	2.3	3.3	152 000	183 000	15 500	18 700	2 600	3 600
64.963	127.000	36.512	36.170	28.575	3.5	3.3	166 000	234 000	16 900	23 900	2 800	3 800

Bearing Numbers		Abutment and Fillet Dimensions (mm)				Eff. Load Centers (mm)	Constant	Axial Load Factors		Mass (kg)	
CONE	CUP	d _a	d _b	D _a	D _b	a	e	Y ₁	Y ₀	approx. CONE	CUP
▲ JLM 508748	▲ JLM 508710	75	66	85	91	5	2.5	21.6	0.40	1.5	0.82
* 39236	39412	71	67	96	100	2.3	2	20.0	0.39	1.5	0.85
397	394 A	69	68	101	104	0.8	1.3	20.9	0.40	1.5	0.82
66585	66520	79	73	105	116	3.5	3.3	34.3	0.67	0.90	0.50
28985	28921	73	67	89	96	3.5	3.3	22.9	0.43	1.4	0.78
28985	28920	73	67	90	97	3.5	3.3	22.9	0.43	1.4	0.78
558	553 X	73	69	108	115	2.3	3.3	28.8	0.35	1.7	0.95
HM 212044	HM 212010	85	70	110	116	8	1.5	27.0	0.34	1.8	0.98
5582	5535	73	72	106	116	0.8	3.3	29.9	0.36	1.7	0.92
65237	65500	82	71	107	119	3.5	3.3	35.0	0.49	1.2	0.68
637	633	78	72	116	124	3.5	3.3	29.9	0.36	1.7	0.91
6376	6320	81	74	117	126	3.5	3.3	35.0	0.32	1.8	1.0
H 715334	H 715311	84	78	119	132	3.5	3.3	37.1	0.47	1.3	0.70
H 913842	H 913810	90	82	124	138	3.5	3.3	44.4	0.78	0.77	0.42
9180	9121	90	81	130	145	3.5	3.3	44.3	0.66	0.92	0.50
L 610549	L 610510	71	69	86	91	1.5	1.5	19.6	0.42	1.4	0.78
39250	39412	73	69	96	100	2	2	20.0	0.39	1.5	0.85
29586	29520	73	71	96	103	1.5	3.3	24.0	0.46	1.3	0.72
395	394 A	77	70	101	104	3.5	1.3	20.9	0.40	1.5	0.82
390 A	394 A	73	70	101	104	1.5	1.3	20.9	0.40	1.5	0.82
3982	3920	77	71	99	106	3.5	3.2	25.5	0.40	1.5	0.82
39585	39520	77	71	101	107	3.5	3.3	23.5	0.34	1.8	0.97
3982	3926	78	71	98	106	3.5	3.3	28.7	0.40	1.5	0.82
HM 212047	HM 212011	87	73	108	116	7	3.3	26.9	0.34	1.8	0.98
HM 212047	HM 212010	87	73	110	116	7	1.5	26.9	0.34	1.8	0.98
HM 212046	HM 212010	80	73	110	116	3.5	1.5	26.9	0.34	1.8	0.98
5584	5535	81	75	106	116	3.5	3.3	29.9	0.36	1.7	0.92
559	522 A	78	73	109	116	3.5	3.3	28.8	0.35	1.7	0.95
565	563	80	73	112	120	3.5	3.3	28.3	0.36	1.6	0.91
639	633	81	74	116	124	3.5	3.3	29.9	0.36	1.7	0.91
78250	78537	85	79	115	130	2.3	3.3	44.2	0.87	0.69	0.38
639	632	79	76	119	125	3.5	3.3	29.9	0.36	1.7	0.91
78250	78551	85	79	117	132	2.3	2.3	44.2	0.87	0.69	0.38
569	563	81	74	112	120	3.5	3.3	28.3	0.36	1.6	0.91

Notes * The maximum bore diameter is listed and its tolerance is negative (See Table 8.4.1 on Page A68).
 ▲ The tolerances are listed in Tables 2, 3 and 4 on Pages B113 and B114.

SINGLE-ROW TAPERED ROLLER BEARINGS (INCH DESIGN)

Bore Diameter 65.000 – 69.850 mm

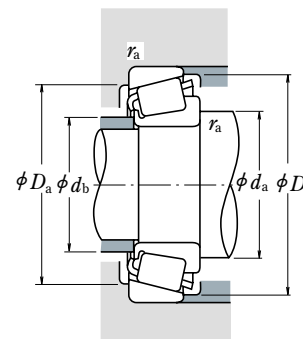
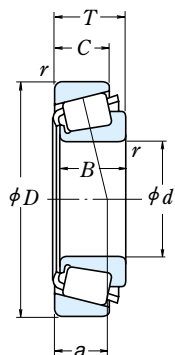

Dynamic Equivalent Load

$$P = XF_r + YF_a$$

$F_a/F_r \leq e$		$F_a/F_r > e$	
X	Y	X	Y
1	0	0.4	Y_1

Static Equivalent Load

$P_0 = 0.5F_r + Y_0F_a$
 When $F_r > 0.5F_r + Y_0F_a$, use $P_0 = F_r$
 The values of e , Y_1 , and Y_0 are given in the table below.

Boundary Dimensions (mm)						Basic Load Ratings (N) (kgf)				Limiting Speeds (min ⁻¹)		
<i>d</i>	<i>D</i>	<i>T</i>	<i>B</i>	<i>C</i>	Cone <i>r</i> min.	Cup	<i>C_r</i>	<i>C_{0r}</i>	<i>C_r</i>	<i>C_{0r}</i>	Grease	Oil
65.000	105.000	24.000	23.000	18.500	3.0	1.0	93 000	126 000	9 500	12 900	3 400	4 500
	110.000	28.000	28.000	22.500	3.0	2.5	120 000	173 000	12 200	17 700	3 200	4 300
	120.000	29.002	29.007	23.444	2.3	3.3	123 000	169 000	12 500	17 200	3 000	4 000
	120.000	39.000	38.500	32.000	3.0	2.5	185 000	249 000	18 800	25 400	3 000	4 000
65.088	135.755	53.975	56.007	44.450	3.5	3.3	264 000	355 000	27 000	36 000	2 800	3 800
	136.525	46.038	46.038	36.512	3.5	3.3	233 000	370 000	23 800	37 500	2 600	3 400
66.675	110.000	22.000	21.996	18.824	0.8	1.3	85 500	113 000	8 750	11 500	3 200	4 300
	110.000	22.000	21.996	18.824	3.5	1.3	85 500	113 000	8 750	11 500	3 200	4 300
	112.712	30.162	30.048	23.812	3.5	3.2	120 000	173 000	12 200	17 700	3 200	4 300
	112.712	30.162	30.048	23.812	5.5	3.2	120 000	173 000	12 200	17 700	3 200	4 300
	112.712	30.162	30.162	23.812	3.5	0.8	142 000	202 000	14 500	20 600	3 200	4 300
	112.712	30.162	30.162	23.812	3.5	3.3	142 000	202 000	14 500	20 600	3 200	4 300
	117.475	30.162	30.162	23.812	3.5	3.3	119 000	179 000	12 200	18 300	3 000	4 000
	122.238	38.100	36.678	30.162	3.5	3.3	161 000	221 000	16 400	22 500	3 000	4 000
	122.238	38.100	38.354	29.718	3.5	1.5	188 000	245 000	19 200	25 000	3 000	4 000
	122.238	38.100	38.354	29.718	3.5	3.3	188 000	245 000	19 200	25 000	3 000	4 000
	123.825	38.100	36.678	30.162	3.5	3.3	161 000	221 000	16 400	22 500	3 000	4 000
	136.525	46.038	46.038	36.512	3.5	3.3	233 000	370 000	23 800	37 500	2 600	3 400
68.262	110.000	22.000	21.996	18.824	2.3	1.3	85 500	113 000	8 750	11 500	3 200	4 300
	120.000	29.795	29.007	24.237	3.5	2.0	123 000	169 000	12 500	17 200	3 000	4 000
	122.238	38.100	36.678	30.162	3.5	3.3	161 000	221 000	16 400	22 500	3 000	4 000
	127.000	36.512	36.170	28.575	3.5	3.3	166 000	234 000	16 900	23 900	2 800	3 800
	136.525	41.275	41.275	31.750	3.5	3.3	229 000	297 000	23 300	30 500	2 600	3 600
	136.525	46.038	46.038	36.512	3.5	3.3	233 000	370 000	23 800	37 500	2 600	3 400
	152.400	47.625	46.038	31.750	3.5	3.3	237 000	267 000	24 200	27 300	2 400	3 400
69.850	112.712	22.225	21.996	15.875	1.5	0.8	85 000	113 000	8 650	11 500	3 000	4 000
	112.712	25.400	25.400	19.050	1.5	3.3	96 000	152 000	9 800	15 500	2 800	4 000
	117.475	30.162	30.162	23.812	3.5	3.3	119 000	179 000	12 200	18 300	3 000	4 000
	120.000	32.545	32.545	26.195	3.5	3.3	152 000	225 000	15 500	22 900	3 000	4 000
	120.650	25.400	25.400	19.050	1.5	3.3	96 000	152 000	9 800	15 500	2 800	4 000
	127.000	36.512	36.170	28.575	3.5	0.8	166 000	234 000	16 900	23 900	2 800	3 800
	130.175	41.275	41.275	31.750	3.5	3.3	195 000	263 000	19 800	26 800	2 800	3 800
	146.050	41.275	39.688	25.400	3.5	3.3	193 000	225 000	19 700	22 900	2 400	3 400
	146.050	41.275	41.275	31.750	3.5	3.3	207 000	296 000	21 100	30 000	2 400	3 200
	149.225	53.975	54.229	44.450	5.0	3.3	287 000	410 000	29 300	41 500	2 600	3 400
	150.089	44.450	46.672	36.512	3.5	3.3	265 000	370 000	27 000	37 500	2 400	3 200

Bearing Numbers		Abutment and Fillet Dimensions (mm)				Cone <i>r_a</i> max.	Eff. Load Centers (mm) <i>a</i>	Constant <i>e</i>	Axial Load Factors		Mass (kg)		
CONE	CUP	<i>d_a</i>	<i>d_b</i>	<i>D_a</i>	<i>D_b</i>				<i>Y₁</i>	<i>Y₀</i>	approx. CONE	CUP	
▲ JLM 710949	▲ JLM 710910	77	71	96	101	3	1	23.7	0.45	1.3	0.73	0.526	0.237
▲ JM 511946	▲ JM 511910	78	72	99	105	3	2.5	24.5	0.40	1.5	0.82	0.72	0.342
478	472 A	77	73	106	114	2.3	3.3	24.3	0.38	1.6	0.86	0.942	0.466
▲ JH 211749	▲ JH 211710	80	74	107	114	3	2.5	27.9	0.34	1.8	0.98	1.25	0.625
6379	6320	84	77	117	126	3.5	3.3	35.0	0.32	1.8	1.0	2.25	1.39
H 715340	H 715311	88	82	118	132	3.5	3.3	37.1	0.47	1.3	0.70	2.4	0.961
395 A	394 A	73	73	101	104	0.8	1.3	20.9	0.40	1.5	0.82	0.528	0.263
395 S	394 A	79	73	101	104	3.5	1.3	20.9	0.40	1.5	0.82	0.524	0.263
3984	3920	80	74	99	106	3.5	3.2	25.5	0.40	1.5	0.82	0.712	0.454
3994	3920	84	74	99	106	5.5	3.2	25.5	0.40	1.5	0.82	0.706	0.454
39590	39521	80	74	103	107	3.5	0.8	23.5	0.34	1.8	0.97	0.822	0.365
39590	39520	80	74	101	107	3.5	3.3	23.5	0.34	1.8	0.97	0.822	0.359
33262	33462	81	75	104	112	3.5	3.3	26.8	0.44	1.4	0.76	0.911	0.442
560	553 X	81	75	108	115	3.5	3.3	28.8	0.35	1.7	0.95	1.14	0.692
HM 212049	HM 212010	82	75	110	116	3.5	1.5	26.9	0.34	1.8	0.98	1.25	0.604
HM 212049	HM 212011	81	74	108	116	3.5	3.3	26.9	0.34	1.8	0.98	1.25	0.598
560	552 A	81	75	109	116	3.5	3.3	28.8	0.35	1.7	0.95	1.14	0.764
H 715341	H 715311	89	83	118	132	3.5	3.3	37.1	0.47	1.3	0.70	2.34	0.961
399 A	394 A	78	74	101	104	2.3	1.3	20.9	0.40	1.5	0.82	0.497	0.263
480	472	83	76	106	113	3.5	2	25.1	0.38	1.6	0.86	0.862	0.493
560 S	553 X	83	76	108	115	3.5	3.3	28.8	0.35	1.7	0.95	1.09	0.692
570	563	83	77	112	120	3.5	3.3	28.3	0.36	1.6	0.91	1.32	0.655
H 414245	H 414210	86	82	121	129	3.5	3.3	30.6	0.36	1.7	0.92	1.95	0.796
H 715343	H 715311	90	84	118	132	3.5	3.3	37.1	0.47	1.3	0.70	2.28	0.961
9185	9121	94	81	130	145	3.5	3.3	44.3	0.66	0.92	0.50	2.53	1.21
LM 613449	LM 613410	78	76	104	107	1.5	0.8	22.1	0.42	1.4	0.79	0.562	0.238
29675	29620	80	77	101	109	1.5	3.3	26.3	0.49	1.2	0.68	0.695	0.273
33275	33462	84	77	104	112	3.5	3.3	26.8	0.44	1.4	0.76	0.83	0.442
47487	47420	84	78	107	114	3.5	3.3	26.0	0.36	1.7	0.92	1.02	0.477
29675	29630	79	78	105	113	1.5	3.3	26.3	0.49	1.2	0.68	0.695	0.489
566	563 X	85	78	114	120	3.5	0.8	28.3	0.36	1.6	0.91	1.27	0.658
643	633	86	80	116	124	3.5	3.3	29.9	0.36	1.7	0.91	1.56	0.712
H 913849	H 913810	95	82	124	138	3.5	3.3	44.4	0.78	0.77	0.42	1.95	0.898
655	653	88	82	131	139	3.5	3.3	33.2	0.41	1.5	0.81	2.35	0.891
6454	6420	94	85	129	140	5	3.3	39.0	0.36	1.7	0.91	2.95	1.63
745 A	742	88	82	134	142	3.5	3.3	32.5	0.33	1.8	1.0	2.82	1.07

Note ▲ The tolerances are listed in Tables 2, 3 and 4 on Pages B113 and B114.

SINGLE-ROW TAPERED ROLLER BEARINGS (INCH DESIGN)

Bore Diameter 70.000 – 76.200 mm

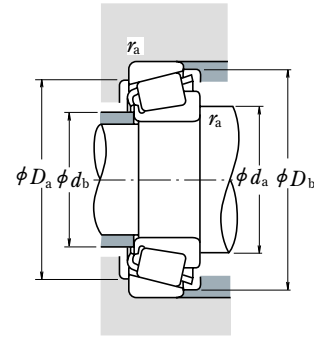
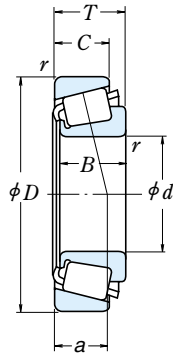

Dynamic Equivalent Load

$$P = X F_r + Y F_a$$

$F_a / F_r \leq e$		$F_a / F_r > e$	
X	Y	X	Y
1	0	0.4	Y_1

Static Equivalent Load

$P_0 = 0.5 F_r + Y_0 F_a$
 When $F_r > 0.5 F_r + Y_0 F_a$, use $P_0 = F_r$
 The values of e , Y_1 , and Y_0 are given in the table below.

d	Boundary Dimensions (mm)					Cone r min.	Cup	Basic Load Ratings (kgf)				Limiting Speeds (min ⁻¹)	
	D	T	B	C	C_r			C_{0r}	C_r	C_{0r}	Grease	Oil	
70.000	110.000	26.000	25.000	20.500	1.0	2.5	98 500	152 000	10 000	15 500	3 000	4 000	
	115.000	29.000	29.000	23.000	3.0	2.5	126 000	177 000	12 900	18 100	3 000	4 000	
	120.000	29.795	29.007	24.237	2.0	2.0	123 000	169 000	12 500	17 200	3 000	4 000	
71.438	117.475	30.162	30.162	23.812	3.5	3.3	119 000	179 000	12 200	18 300	3 000	4 000	
	120.000	32.545	32.545	26.195	3.5	3.3	152 000	225 000	15 500	22 900	3 000	4 000	
	127.000	36.512	36.170	28.575	6.4	3.3	166 000	234 000	16 900	23 900	2 800	3 800	
	127.000	36.512	36.170	28.575	3.5	3.3	166 000	234 000	16 900	23 900	2 800	3 800	
	130.175	41.275	41.275	31.750	6.4	3.3	195 000	263 000	19 800	26 800	2 800	3 800	
	136.525	41.275	41.275	31.750	3.5	3.3	195 000	263 000	19 800	26 800	2 800	3 800	
	136.525	41.275	41.275	31.750	3.5	3.3	229 000	297 000	23 300	30 500	2 600	3 600	
	136.525	46.038	46.038	36.512	3.5	3.3	233 000	370 000	23 800	37 500	2 600	3 400	
	73.025	112.712	25.400	25.400	19.050	3.5	3.3	96 000	152 000	9 800	15 500	2 800	4 000
		117.475	30.162	30.162	23.812	3.5	3.3	119 000	179 000	12 200	18 300	3 000	4 000
127.000		36.512	36.170	28.575	3.5	3.3	166 000	234 000	16 900	23 900	2 800	3 800	
73.817	146.050	41.275	41.275	31.750	3.5	3.3	207 000	296 000	21 100	30 000	2 400	3 200	
	149.225	53.975	54.229	44.450	3.5	3.3	287 000	410 000	29 300	41 500	2 600	3 400	
74.612	127.000	36.512	36.170	28.575	0.8	3.3	166 000	234 000	16 900	23 900	2 800	3 800	
	150.000	41.275	41.275	31.750	3.5	3.0	207 000	296 000	21 100	30 000	2 400	3 200	
75.000	115.000	25.000	25.000	19.000	3.0	2.5	101 000	150 000	10 300	15 300	3 000	4 000	
	120.000	31.000	29.500	25.000	3.0	2.5	129 000	198 000	13 100	20 200	2 800	3 800	
	145.000	51.000	51.000	42.000	3.0	2.5	283 000	410 000	28 900	41 500	2 600	3 400	
76.200	121.442	24.608	23.012	17.462	2.0	2.0	89 000	124 000	9 100	12 600	2 800	3 800	
	127.000	30.162	31.000	22.225	3.5	3.3	134 000	195 000	13 700	19 900	2 800	3 800	
	127.000	30.162	31.001	22.225	6.4	3.3	134 000	195 000	13 700	19 900	2 800	3 800	
	133.350	33.338	33.338	26.195	0.8	3.3	154 000	237 000	15 700	24 200	2 600	3 600	
	135.733	44.450	46.101	34.925	3.5	3.3	216 000	340 000	22 000	35 000	2 600	3 600	
	136.525	30.162	29.769	22.225	3.5	3.3	130 000	192 000	13 300	19 600	2 600	3 400	
	136.525	30.162	29.769	22.225	6.4	3.3	130 000	192 000	13 300	19 600	2 600	3 400	
	139.992	36.512	36.098	28.575	3.5	3.3	175 000	260 000	17 800	26 500	2 600	3 400	
	149.225	53.975	54.229	44.450	3.5	3.3	287 000	410 000	29 300	41 500	2 600	3 400	
	152.400	39.688	36.322	30.162	3.5	3.2	183 000	285 000	18 700	29 100	2 200	3 200	
	152.400	41.275	41.275	31.750	3.5	3.3	207 000	296 000	21 100	30 000	2 400	3 200	
	161.925	49.212	46.038	31.750	3.5	3.3	248 000	290 000	25 300	29 600	2 200	3 000	
	161.925	53.975	55.100	42.862	3.5	3.3	325 000	480 000	33 000	49 000	2 200	3 000	
	161.925	53.975	55.100	42.862	6.4	3.3	325 000	480 000	33 000	49 000	2 200	3 000	
	161.925	53.975	55.100	42.862	6.4	0.8	325 000	480 000	33 000	49 000	2 200	3 000	

Bearing Numbers		Abutment and Fillet Dimensions (mm)				Cone r _a max.	Cup	Eff. Load Centers (mm) a	Constant e	Axial Load Factors		Mass (kg)	
CONE	CUP	d _a	d _b	D _a	D _b					Y ₁	Y ₀		approx. CONE
▲ JLM 813049	▲ JLM 813010	78	77	98	105	1	2.5	26.2	0.49	1.2	0.68	0.604	0.304
▲ JM 612949	▲ JM 612910	83	77	103	110	3	2.5	26.4	0.43	1.4	0.77	0.800	0.362
484	472	80	78	106	113	2	2	25.1	0.38	1.6	0.86	0.822	0.493
33281	33462	85	79	104	112	3.5	3.3	26.8	0.44	1.4	0.76	0.789	0.442
47490	47420	86	79	107	114	3.5	3.3	26.0	0.36	1.7	0.92	0.983	0.477
567 S	563	92	80	112	120	6.4	3.3	28.3	0.36	1.6	0.91	1.21	0.655
567 A	563	86	80	112	120	3.5	3.3	28.3	0.36	1.6	0.91	1.23	0.655
645	633	93	81	116	124	6.4	3.3	29.9	0.36	1.7	0.91	1.49	0.712
644	632	87	81	118	125	3.5	3.3	29.9	0.36	1.7	0.91	1.5	1.04
H 414249	H 414210	89	83	121	129	3.5	3.3	30.6	0.36	1.7	0.92	1.83	0.796
H 715345	H 715311	92	84	119	132	3.5	3.3	37.1	0.47	1.3	0.70	2.15	0.961
29685	29620	86	80	101	109	3.5	3.3	26.3	0.49	1.2	0.68	0.62	0.273
33287	33462	87	80	104	112	3.5	3.3	26.8	0.44	1.4	0.76	0.746	0.442
567	563	88	81	112	120	3.5	3.3	28.3	0.36	1.6	0.91	1.17	0.655
657	653	91	85	131	139	3.5	3.3	33.2	0.41	1.5	0.81	2.24	0.891
6460	6420	93	87	129	140	3.5	3.3	39.0	0.36	1.7	0.91	2.8	1.63
568	563	83	82	112	120	0.8	3.3	28.3	0.36	1.6	0.91	1.15	0.655
658	653 X	92	86	133	141	3.5	3	33.2	0.41	1.5	0.81	2.37	0.932
▲ JLM 714149	▲ JLM 714110	87	81	104	110	3	2.5	25.3	0.46	1.3	0.72	0.638	0.272
▲ JM 714249	▲ JM 714210	88	83	108	115	3	2.5	28.8	0.44	1.4	0.74	0.863	0.436
▲ JH 415647	▲ JH 415610	94	89	129	139	3	2.5	36.7	0.36	1.7	0.91	2.64	1.19
34300	34478	86	84	111	116	2	2	26.3	0.45	1.3	0.73	0.65	0.316
42687	42620	90	84	114	121	3.5	3.3	27.3	0.42	1.4	0.79	1.03	0.438
42688	42620	94	84	114	121	6.4	3.3	27.3	0.42	1.4	0.79	1.01	0.438
47680	47620	86	85	119	128	0.8	3.3	29.0	0.40	1.5	0.82	1.39	0.577
5760	5735	94	88	119	130	3.5	3.3	32.9	0.41	1.5	0.81	1.86	0.887
495 A	493	92	86	122	130	3.5	3.3	28.7	0.44	1.4	0.74	1.27	0.55
495 AX	493	98	86	122	130	6.4	3.3	28.7	0.44	1.4	0.74	1.26	0.55
575	572	92	86	125	133	3.5	3.3	31.1	0.40	1.5	0.82	1.61	0.788
6461	6420	96	89	129	140	3.5	3.3	39.0	0.36	1.7	0.91	2.64	1.63
590 A	592 A	95	89	135	145	3.5	3.2	37.1	0.44	1.4	0.75	2.2	1.06
659	652	93	87	134	141	3.5	3.3	33.2	0.41	1.5	0.81	2.11	1.26
9285	9220	103	90	138	153	3.5	3.3	49.8	0.71	0.85	0.47	2.82	1.4
6576	6535	99	92	141	154	3.5	3.3	40.7	0.40	1.5	0.82	3.74	1.67
6575	6535	104	92	141	154	6.4	3.3	40.7	0.40	1.5	0.82	3.73	1.67
6575	6536	104	92	144	154	6.4	0.8	40.7	0.40	1.5	0.82	3.73	1.68

Note ▲ The tolerances are listed in Tables 2, 3 and 4 on Pages B113 and B114.

SINGLE-ROW TAPERED ROLLER BEARINGS (INCH DESIGN)

Bore Diameter 76.200 – 83.345 mm

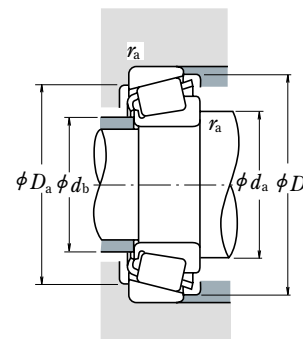
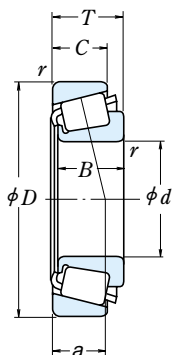

Dynamic Equivalent Load

$$P = X F_r + Y F_a$$

$F_a/F_r \leq e$		$F_a/F_r > e$	
X	Y	X	Y
1	0	0.4	Y_1

Static Equivalent Load

$P_0 = 0.5 F_r + Y_0 F_a$
 When $F_r > 0.5 F_r + Y_0 F_a$, use $P_0 = F_r$
 The values of e , Y_1 , and Y_0 are given in the table below.

d	Boundary Dimensions (mm)					Cone r min.	Cup	Basic Load Ratings (N) (kgf)				Limiting Speeds (min ⁻¹)	
	D	T	B	C	C _r			C _{0r}	C _r	C _{0r}	Grease	Oil	
76.200	168.275	53.975	56.363	41.275	6.4	3.3	345 000	470 000	35 000	48 000	2 200	3 000	
	168.275	53.975	56.363	41.275	0.8	3.3	345 000	470 000	35 000	48 000	2 200	3 000	
	171.450	49.212	46.038	31.750	3.5	3.3	257 000	310 000	26 200	32 000	2 000	2 800	
	177.800	55.562	50.800	34.925	3.5	3.3	257 000	310 000	26 200	32 000	2 000	2 800	
77.788	121.442	24.608	23.012	17.462	3.5	2.0	89 000	124 000	9 100	12 600	2 800	3 800	
	127.000	30.162	31.000	22.225	3.5	3.3	134 000	195 000	13 700	19 900	2 800	3 800	
	135.733	44.450	46.101	34.925	3.5	3.3	216 000	340 000	22 000	35 000	2 600	3 600	
79.375	146.050	41.275	41.275	31.750	3.5	3.3	207 000	296 000	21 100	30 000	2 400	3 200	
	150.089	44.450	46.672	36.512	3.5	3.3	265 000	370 000	27 000	37 500	2 400	3 200	
80.000	130.000	35.000	34.000	28.500	3.0	2.5	166 000	251 000	17 000	25 600	2 600	3 600	
80.962	136.525	30.162	29.769	22.225	3.5	3.3	130 000	192 000	13 300	19 600	2 600	3 400	
	139.700	36.512	36.098	28.575	3.5	3.3	175 000	260 000	17 800	26 500	2 600	3 400	
	139.992	36.512	36.098	28.575	3.5	3.3	175 000	260 000	17 800	26 500	2 600	3 400	
	139.992	36.512	36.098	28.575	3.5	3.3	175 000	260 000	17 800	26 500	2 600	3 400	
82.550	125.412	25.400	25.400	19.845	3.5	1.5	102 000	164 000	10 400	16 700	2 600	3 600	
	133.350	30.162	29.769	22.225	3.5	3.3	130 000	192 000	13 300	19 600	2 600	3 400	
	133.350	33.338	33.338	26.195	3.5	3.3	154 000	237 000	15 700	24 200	2 600	3 600	
	133.350	33.338	33.338	26.195	0.8	3.3	154 000	237 000	15 700	24 200	2 600	3 600	
	133.350	39.688	39.688	32.545	6.8	3.3	179 000	310 000	18 300	31 500	2 600	3 600	
	136.525	30.162	29.769	22.225	3.5	3.3	130 000	192 000	13 300	19 600	2 600	3 400	
	139.700	36.512	36.098	28.575	3.5	3.3	175 000	260 000	17 800	26 500	2 600	3 400	
	139.992	36.512	36.098	28.575	3.5	3.3	175 000	260 000	17 800	26 500	2 600	3 400	
	139.992	36.512	36.098	28.575	6.8	3.3	175 000	260 000	17 800	26 500	2 600	3 400	
	146.050	41.275	41.275	31.750	3.5	3.3	207 000	296 000	21 100	30 000	2 400	3 200	
	150.000	44.455	46.672	35.000	3.5	3.3	265 000	370 000	27 000	37 500	2 400	3 200	
	150.089	44.450	46.672	36.512	3.5	3.3	265 000	370 000	27 000	37 500	2 400	3 200	
152.400	41.275	41.275	31.750	3.5	3.3	207 000	296 000	21 100	30 000	2 400	3 200		
161.925	47.625	48.260	38.100	3.5	3.3	274 000	390 000	28 000	40 000	2 200	3 000		
161.925	53.975	55.100	42.862	3.5	3.3	325 000	480 000	33 000	49 000	2 200	3 000		
168.275	47.625	48.260	38.100	3.5	3.3	274 000	390 000	28 000	40 000	2 200	3 000		
168.275	53.975	56.363	41.275	3.5	3.3	345 000	470 000	35 000	48 000	2 200	3 000		
83.345	125.412	25.400	25.400	19.845	3.5	1.5	102 000	164 000	10 400	16 700	2 600	3 600	
	125.412	25.400	25.400	19.845	0.8	1.5	102 000	164 000	10 400	16 700	2 600	3 600	

Bearing Numbers		Abutment and Fillet Dimensions (mm)					Eff. Load Centers (mm) a	Constant e	Axial Load Factors		Mass (kg)		
CONE	CUP	d _a	d _b	D _a	D _b	Cone r _a max.			Y ₁	Y ₀	CONE approx.	CUP	
843	832	101	89	149	155	6.4	3.3	35.2	0.30	2.0	1.1	4.11	1.74
837	832	90	89	149	155	0.8	3.3	35.2	0.30	2.0	1.1	4.13	1.74
9380	9321	105	98	147	164	3.5	3.3	54.1	0.76	0.79	0.43	3.47	1.51
9378	9320	105	98	148	164	3.5	3.3	57.3	0.76	0.79	0.43	3.71	2.24
34306	34478	90	84	110	116	3.5	2	26.3	0.45	1.3	0.73	0.612	0.316
42690	42620	91	85	114	121	3.5	3.3	27.3	0.42	1.4	0.79	0.976	0.438
5795	5735	96	89	119	130	3.5	3.3	32.9	0.41	1.5	0.81	1.79	0.887
661	653	96	90	131	139	3.5	3.3	33.2	0.41	1.5	0.81	1.99	0.891
750	742	96	90	134	142	3.5	3.3	32.5	0.33	1.8	1.0	2.42	1.07
▲ JM 515649	▲ JM 515610	94	88	117	125	3	2.5	29.9	0.39	1.5	0.85	1.18	0.583
496	493	95	89	122	130	3.5	3.3	28.7	0.44	1.4	0.74	1.13	0.55
581	572 X	96	90	125	133	3.5	3.3	31.1	0.40	1.5	0.82	1.44	0.774
581	572	96	90	125	133	3.5	3.3	31.1	0.40	1.5	0.82	1.44	0.788
27687	27620	96	89	115	120	3.5	1.5	25.7	0.42	1.4	0.79	0.747	0.348
495	492 A	97	90	120	128	3.5	3.3	28.7	0.44	1.4	0.74	1.08	0.434
47686	47620	97	90	119	128	3.5	3.3	29.0	0.40	1.5	0.82	1.18	0.577
47685	47620	90	90	119	128	0.8	3.3	29.0	0.40	1.5	0.82	1.18	0.577
47687	47620	103	90	119	128	6.8	3.3	29.0	0.40	1.5	0.82	1.16	0.577
HM 516448	HM 516410	105	92	118	128	6.8	3.3	32.4	0.40	1.5	0.82	1.35	0.767
495	493	97	90	122	130	3.5	3.3	28.7	0.44	1.4	0.74	1.08	0.55
580	572 X	98	91	125	133	3.5	3.3	31.1	0.40	1.5	0.82	1.39	0.774
580	572	98	91	125	133	3.5	3.3	31.1	0.40	1.5	0.82	1.39	0.788
582	572	104	91	125	133	6.8	3.3	31.1	0.40	1.5	0.82	1.37	0.788
663	653	99	92	131	139	3.5	3.3	33.2	0.41	1.5	0.81	1.85	0.891
749 A	743	99	93	134	142	3.5	3.3	32.5	0.33	1.8	1.0	2.26	1.04
749 A	742	98	93	135	143	3.5	3.3	32.5	0.33	1.8	1.0	2.26	1.07
663	652	99	92	134	141	3.5	3.3	33.2	0.41	1.5	0.81	1.85	1.26
757	752	100	94	144	150	3.5	3.3	35.6	0.34	1.8	0.97	2.79	1.61
6559	6535	104	98	141	154	3.5	3.3	40.7	0.40	1.5	0.82	3.4	1.67
757	753	100	94	147	150	3.5	3.3	35.6	0.34	1.8	0.97	2.79	2.1
842	832	101	94	149	155	3.5	3.3	35.2	0.30	2.0	1.1	3.76	1.74
27690	27620	96	90	115	120	3.5	1.5	25.7	0.42	1.4	0.79	0.727	0.348
27689	27620	90	90	115	120	0.8	1.5	25.7	0.42	1.4	0.79	0.732	0.348

Note ▲ The tolerances are listed in Tables 2, 3 and 4 on Pages B113 and B114.

SINGLE-ROW TAPERED ROLLER BEARINGS (INCH DESIGN)

Bore Diameter 84.138 – 90.488 mm

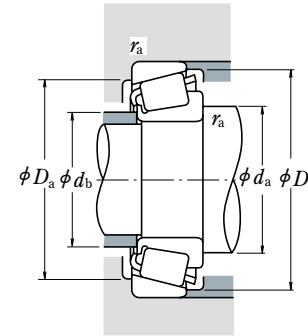
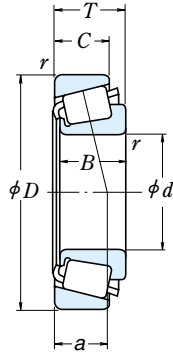

Dynamic Equivalent Load

$$P = XF_r + YF_a$$

$F_a/F_r \leq e$		$F_a/F_r > e$	
X	Y	X	Y
1	0	0.4	Y_1

Static Equivalent Load

$P_0 = 0.5F_r + Y_0F_a$
 When $F_r > 0.5F_r + Y_0F_a$, use $P_0 = F_r$
 The values of e , Y_1 , and Y_0 are given in the table below.

d	Boundary Dimensions (mm)					Cone r min.	Cup r	Basic Load Ratings (N) (kgf)				Limiting Speeds (min ⁻¹)	
	D	T	B	C	C _r			C _{0r}	C _r	C _{0r}	Grease	Oil	
84.138	136.525	30.162	29.769	22.225	3.5	3.3	130 000	192 000	13 300	19 600	2 600	3 400	
	146.050	41.275	41.275	31.750	3.5	3.3	207 000	296 000	21 100	30 000	2 400	3 200	
	171.450	49.212	46.038	31.750	3.5	3.3	257 000	310 000	26 200	32 000	2 000	2 800	
85.000	130.000	30.000	29.000	24.000	6.0	2.5	138 000	222 000	14 100	22 700	2 600	3 600	
	130.000	30.000	29.000	24.000	3.0	2.5	138 000	222 000	14 100	22 700	2 600	3 600	
	140.000	39.000	38.000	31.500	3.0	2.5	202 000	305 000	20 600	31 000	2 400	3 400	
	150.000	46.000	46.000	38.000	3.0	2.5	275 000	390 000	28 000	40 000	2 400	3 200	
85.026	150.089	44.450	46.672	36.512	3.5	3.3	265 000	370 000	27 000	37 500	2 400	3 200	
	150.089	44.450	46.672	36.512	5.0	3.3	265 000	370 000	27 000	37 500	2 400	3 200	
85.725	133.350	30.162	29.769	22.225	3.5	3.3	130 000	192 000	13 300	19 600	2 600	3 400	
	136.525	30.162	29.769	22.225	3.5	3.3	130 000	192 000	13 300	19 600	2 600	3 400	
	142.138	42.862	42.862	34.133	4.8	3.3	221 000	360 000	22 500	36 500	2 400	3 400	
146.050	41.275	41.275	31.750	6.4	3.3	207 000	296 000	21 100	30 000	2 400	3 200		
	146.050	41.275	41.275	31.750	3.5	3.3	207 000	296 000	21 100	30 000	2 400	3 200	
	152.400	39.688	36.322	30.162	3.5	3.2	183 000	285 000	18 700	29 100	2 200	3 200	
	161.925	47.625	48.260	38.100	3.5	3.3	274 000	390 000	28 000	40 000	2 200	3 000	
	168.275	41.275	41.275	30.162	3.5	3.3	223 000	345 000	22 700	35 000	2 000	2 800	
87.312	190.500	57.150	57.531	46.038	8.0	3.3	390 000	520 000	39 500	53 500	1 900	2 600	
88.900	149.225	31.750	28.971	24.608	3.0	3.2	140 000	218 000	14 300	22 300	2 200	3 000	
	152.400	39.688	36.322	30.162	3.5	3.2	183 000	285 000	18 700	29 100	2 200	3 200	
	152.400	39.688	39.688	30.162	6.4	3.3	253 000	365 000	25 800	37 500	2 200	3 200	
161.925	47.625	48.260	38.100	3.5	3.3	274 000	390 000	28 000	40 000	2 200	3 000		
	161.925	47.625	48.260	38.100	7.0	3.3	274 000	390 000	28 000	40 000	2 200	3 000	
	161.925	53.975	55.100	42.862	3.5	3.3	325 000	480 000	33 000	49 000	2 200	3 000	
	168.275	47.625	48.260	38.100	3.5	3.3	274 000	390 000	28 000	40 000	2 200	3 000	
	168.275	53.975	56.363	41.275	3.5	3.3	345 000	470 000	35 000	48 000	2 200	3 000	
190.500	57.150	57.531	44.450	8.0	3.3	355 000	500 000	36 000	51 000	1 900	2 600		
	190.500	57.150	57.531	46.038	8.0	3.3	390 000	520 000	39 500	53 500	1 900	2 600	
90.000	145.000	35.000	34.000	27.000	3.0	2.5	190 000	285 000	19 400	29 000	2 400	3 200	
	147.000	40.000	40.000	32.500	7.0	3.5	229 000	345 000	23 400	35 000	2 400	3 200	
	155.000	44.000	44.000	35.500	3.0	2.5	274 000	395 000	28 000	40 000	2 200	3 000	
90.488	161.925	47.625	48.260	38.100	3.5	3.3	274 000	390 000	28 000	40 000	2 200	3 000	

Bearing Numbers		Abutment and Fillet Dimensions (mm)					Eff. Load Centers (mm) a	Constant e	Axial Load Factors		Mass (kg)		
CONE	CUP	d _a	d _b	D _a	D _b	Cone r _a max.			Y ₁	Y ₀	approx. CONE	CUP	
498 664 9385	493 653 9321	98	91	122	130	3.5	3.3	28.7	0.44	1.4	0.74	1.04	0.55
		99	93	131	139	3.5	3.3	33.2	0.41	1.5	0.81	1.79	0.891
		111	98	147	164	3.5	3.3	54.1	0.76	0.79	0.43	3.11	1.51
▲ JM 716648 ▲ JM 716649 ▲ JHM 516849 ▲ JH 217249	▲ JM 716610 ▲ JM 716610 ▲ JHM 516810 ▲ JH 217210	104	92	117	125	6	2.5	29.5	0.44	1.4	0.74	0.931	0.461
		98	92	117	125	3	2.5	29.5	0.44	1.4	0.74	0.943	0.461
		100	94	125	134	3	2.5	33.3	0.41	1.5	0.81	1.55	0.768
		101	95	134	142	3	2.5	33.9	0.33	1.8	0.99	2.29	1.09
749 749 S	742 742	101	95	134	142	3.5	3.3	32.5	0.33	1.8	1.0	2.14	1.07
		104	95	134	142	5	3.3	32.5	0.33	1.8	1.0	2.14	1.07
497 497 HM 617049	492 A 493 HM 617010	99	93	120	128	3.5	3.3	28.7	0.44	1.4	0.74	0.987	0.434
		99	93	122	130	3.5	3.3	28.7	0.44	1.4	0.74	0.987	0.55
		106	95	125	137	4.8	3.3	35.4	0.43	1.4	0.76	1.77	0.911
665 A 665 596	653 653 592 A	107	95	131	139	6.4	3.3	33.2	0.41	1.5	0.81	1.71	0.891
		102	95	131	139	3.5	3.3	33.2	0.41	1.5	0.81	1.72	0.891
		102	96	135	144	3.5	3.2	37.1	0.44	1.4	0.75	1.85	1.06
758 677	752 672	103	97	144	150	3.5	3.3	35.6	0.34	1.8	0.97	2.63	1.61
		105	99	149	160	3.5	3.3	38.3	0.47	1.3	0.70	2.91	1.24
HH 221432	HH 221410	118	103	171	179	8	3.3	42.3	0.33	1.8	0.99	5.51	2.24
		104	98	134	143	3	3.3	34.9	0.49	1.2	0.67	1.39	0.711
		104	98	135	144	3.5	3.2	37.1	0.44	1.4	0.75	1.73	1.06
HM 518445	HM 518410	107	96	137	148	6.4	3.3	33.1	0.40	1.5	0.82	2.11	0.776
		106	99	144	150	3.5	3.3	35.6	0.34	1.8	0.97	2.47	1.61
759 766 6580	752 752 6535	113	99	144	150	7	3.3	35.6	0.34	1.8	0.97	2.45	1.61
		109	102	141	154	3.5	3.3	40.7	0.40	1.5	0.82	3.03	1.67
		106	99	147	150	3.5	3.3	35.6	0.34	1.8	0.97	2.47	2.1
759 850	753 832	106	99	147	150	3.5	3.3	35.6	0.34	1.8	0.97	2.47	2.1
		106	100	149	155	3.5	3.3	35.2	0.30	2.0	1.1	3.39	1.74
855 HH 221434	854 HH 221410	118	103	170	174	8	3.3	41.8	0.33	1.8	0.99	4.99	2.55
		120	105	171	179	8	3.3	42.3	0.33	1.8	0.99	5.41	2.24
▲ JM 718149 *HM 218248 ▲ JHM 318448	▲ JM 718110 **HM 218210 ▲ JHM 318410	105	99	131	139	3	2.5	33.0	0.44	1.4	0.74	1.49	0.66
		111	98	133	141	7	3.5	30.8	0.33	1.8	0.99	1.77	0.796
		106	100	140	148	3	2.5	34.1	0.34	1.7	0.96	2.32	1.01
760	752	107	101	144	150	3.5	3.3	35.6	0.34	1.8	0.97	2.38	1.61

- Notes
- * The maximum bore diameter is listed and its tolerance is negative (See Table 8.4.1 on Page A68).
 - ** The maximum outside diameter is listed and its tolerance is negative (See Table 8.4.2 on Pages A68 and A69).
 - ▲ The tolerances are listed in Tables 2, 3 and 4 on Pages B113 and B114.

SINGLE-ROW TAPERED ROLLER BEARINGS (INCH DESIGN)

Bore Diameter 92.075 – 100.012 mm

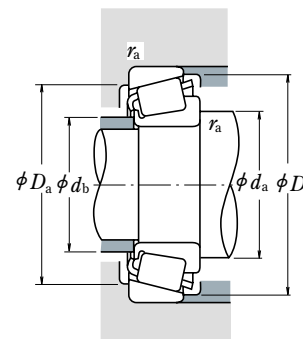
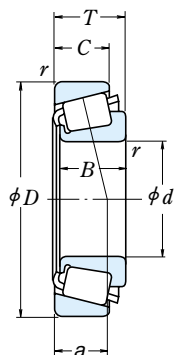

Dynamic Equivalent Load

$$P = X F_r + Y F_a$$

$F_a/F_r \leq e$		$F_a/F_r > e$	
X	Y	X	Y
1	0	0.4	Y_1

Static Equivalent Load

$P_0 = 0.5 F_r + Y_0 F_a$
 When $F_r > 0.5 F_r + Y_0 F_a$, use $P_0 = F_r$
 The values of e , Y_1 , and Y_0 are given in the table below.

d	Boundary Dimensions (mm)					Cone r min.	Cup r	Basic Load Ratings (N) {kgf}				Limiting Speeds (min ⁻¹)	
	D	T	B	C	C _r			C _{0r}	C _r	C _{0r}	Grease	Oil	
92.075	146.050	33.338	34.925	26.195	3.5	3.3	169 000	280 000	17 300	28 500	2 400	3 200	
	148.430	28.575	28.971	21.433	3.5	3.0	140 000	218 000	14 300	22 300	2 200	3 000	
	152.400	39.688	36.322	30.162	3.5	3.2	183 000	285 000	18 700	29 100	2 200	3 200	
93.662	148.430	28.575	28.971	21.433	3.0	3.0	140 000	218 000	14 300	22 300	2 200	3 000	
	149.225	31.750	28.971	24.608	3.0	3.3	140 000	218 000	14 300	22 300	2 200	3 000	
	152.400	39.688	36.322	30.162	3.5	3.2	183 000	285 000	18 700	29 100	2 200	3 200	
95.000	150.000	35.000	34.000	27.000	3.0	2.5	183 000	285 000	18 700	29 100	2 200	3 200	
	146.050	33.338	34.925	26.195	3.5	3.3	169 000	280 000	17 300	28 500	2 400	3 200	
	148.430	28.575	28.971	21.433	3.0	3.0	140 000	218 000	14 300	22 300	2 200	3 000	
95.250	149.225	31.750	28.971	24.608	3.5	3.3	140 000	218 000	14 300	22 300	2 200	3 000	
	152.400	39.688	36.322	30.162	3.5	3.2	183 000	285 000	18 700	29 100	2 200	3 200	
	152.400	39.688	36.322	30.162	3.5	3.2	183 000	285 000	18 700	29 100	2 200	3 200	
96.838	148.430	28.575	28.971	21.433	3.5	3.0	140 000	218 000	14 300	22 300	2 200	3 000	
	149.225	31.750	28.971	24.606	3.5	3.3	140 000	218 000	14 300	22 300	2 200	3 000	
	148.430	28.575	28.971	21.433	3.5	3.0	140 000	218 000	14 300	22 300	2 200	3 000	
98.425	161.925	36.512	36.116	26.195	3.5	3.3	191 000	310 000	19 500	31 500	2 000	2 800	
	168.275	41.275	48.006	38.100	3.5	3.3	223 000	345 000	22 700	35 000	2 000	2 800	
	180.975	47.625	48.006	38.100	3.5	3.3	258 000	375 000	26 300	38 500	2 000	2 600	
99.982	190.500	57.150	57.531	44.450	3.5	3.3	355 000	500 000	36 000	51 000	1 900	2 600	
	190.500	57.150	57.531	46.038	3.5	3.3	390 000	520 000	39 500	53 500	1 900	2 600	
	190.500	57.150	57.531	46.038	6.4	3.3	390 000	520 000	39 500	53 500	1 900	2 600	
100.000	150.000	32.000	30.000	26.000	2.3	2.3	146 000	235 000	14 900	24 000	2 200	3 000	
	155.000	36.000	35.000	28.000	3.0	2.5	191 000	325 000	19 500	33 000	2 000	2 800	
	160.000	41.000	40.000	32.000	3.0	2.5	239 000	380 000	24 400	38 500	2 000	2 800	
100.012	157.162	36.512	36.116	26.195	3.5	3.3	191 000	310 000	19 500	31 500	2 000	2 800	

Bearing Numbers		Abutment and Fillet Dimensions (mm)				Cone r _a max.	Cup r _a max.	Eff. Load Centers (mm) a	Constant e	Axial Load Factors		Mass (kg)	
CONE	CUP	d _a	d _b	D _a	D _b					Y ₁	Y ₀	approx. CONE	CUP
47890 42362 598	47820 42584 592 A	107	101	131	140	3.5	3.3	32.3	0.45	1.3	0.74	1.46	0.664
		107	101	134	142	3.5	3	31.8	0.49	1.2	0.67	1.29	0.553
		107	101	135	144	3.5	3.2	37.1	0.44	1.4	0.75	1.6	1.06
598 A 681 857	592 A 672 854	113	101	135	144	6.4	3.2	37.1	0.44	1.4	0.75	1.59	1.06
		110	104	149	160	3.5	3.3	38.3	0.47	1.3	0.70	2.62	1.24
		121	106	170	174	8	3.3	41.8	0.33	1.8	0.99	4.78	2.55
42368 42368 597	42584 42587 592 A	107	102	134	142	3	3	31.8	0.49	1.2	0.67	1.24	0.553
		107	102	134	143	3	3.3	34.9	0.49	1.2	0.67	1.24	0.711
		109	102	135	144	3.5	3.2	37.1	0.44	1.4	0.75	1.54	1.06
▲ JM 719149	▲ JM 719113	109	104	135	143	3	2.5	33.4	0.44	1.4	0.75	1.46	0.765
47896 42375 42376	47820 42584 42587	110	103	131	140	3.5	3.3	32.3	0.45	1.3	0.74	1.33	0.664
		108	103	134	142	3	3	31.8	0.49	1.2	0.67	1.18	0.553
		109	103	134	143	3.5	3.3	34.9	0.49	1.2	0.67	1.18	0.711
594 594 683	592 A 592 672	110	104	135	144	3.5	3.2	37.1	0.44	1.4	0.75	1.47	1.06
		109	103	135	145	3.5	3.3	37.1	0.44	1.4	0.75	1.47	1.12
		113	106	149	160	3.5	3.3	38.3	0.47	1.3	0.70	2.47	1.24
77375 776 864	77675 772 854	117	105	152	159	3.5	3.3	37.8	0.37	1.6	0.90	2.91	1.67
		114	107	161	168	3.5	3.3	39.1	0.39	1.6	0.86	3.25	1.99
		123	108	170	174	8	3.3	41.8	0.33	1.8	0.99	4.57	2.55
HH 221440	HH 221410	125	110	171	179	8	3.3	42.3	0.33	1.8	0.99	5.0	2.24
42381 42381	42584 42587	110	104	134	142	3.5	3	31.8	0.49	1.2	0.67	1.13	0.553
		111	105	135	143	3.5	3.3	34.9	0.49	1.2	0.67	1.13	0.711
		114	108	144	154	3.5	3.3	36.1	0.47	1.3	0.69	1.89	0.942
52387 685 779	52637 672 772	116	109	149	160	3.5	3.3	38.3	0.47	1.3	0.70	2.32	1.24
		116	110	161	168	3.5	3.3	39.1	0.39	1.6	0.86	3.06	1.99
		118	111	170	174	3.5	3.3	41.8	0.33	1.8	0.99	4.38	2.55
HH 221442	HH 221410	119	113	171	179	3.5	3.3	42.3	0.33	1.8	0.99	4.81	2.24
HH 221447	HH 221410	126	114	171	179	6.4	3.3	42.3	0.33	1.8	0.99	4.68	2.24
▲ JLM 820048	▲ JLM 820012	111	107	135	144	2.3	2.3	36.8	0.50	1.2	0.66	1.27	0.616
▲ JM 720249	▲ JM 720210	115	109	140	149	3	2.5	36.8	0.47	1.3	0.70	1.68	0.772
▲ JHM 720249	▲ JHM 720210	117	109	143	154	3	2.5	38.2	0.47	1.3	0.70	2.09	0.974
52393	52618	116	109	142	152	3.5	3.3	36.1	0.47	1.3	0.69	1.81	0.702

Note ▲ The tolerances are listed in Tables 2, 3 and 4 on Pages B113 and B114.

SINGLE-ROW TAPERED ROLLER BEARINGS (INCH DESIGN)

Bore Diameter 101.600 – 117.475 mm

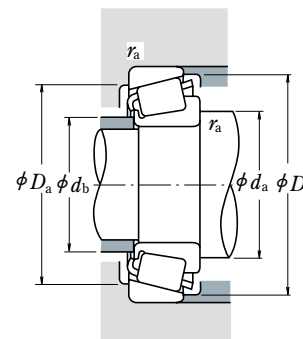
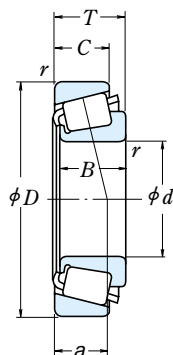

Dynamic Equivalent Load

$$P = X F_r + Y F_a$$

$F_a/F_r \leq e$		$F_a/F_r > e$	
X	Y	X	Y
1	0	0.4	Y_1

Static Equivalent Load

$$P_0 = 0.5 F_r + Y_0 F_a$$

When $F_r > 0.5 F_r + Y_0 F_a$, use $P_0 = F_r$

The values of e , Y_1 , and Y_0 are given in the table below.

	Boundary Dimensions (mm)					Cone r min.	Cup r max.	Basic Load Ratings (N)				Limiting Speeds (min ⁻¹)	
	d	D	T	B	C			C_r	C_{0r}	C_r	C_{0r}	Grease	Oil
101.600	157.162	36.512	36.116	26.195	3.5	3.3	191 000	310 000	19 500	31 500	2 000	2 800	
	161.925	36.512	36.116	26.195	3.5	3.3	191 000	310 000	19 500	31 500	2 000	2 800	
	168.275	41.275	41.275	30.162	3.5	3.3	223 000	345 000	22 700	35 000	2 000	2 800	
180.975	47.625	48.006	38.100	3.5	3.3	258 000	375 000	26 300	38 500	2 000	2 600		
	57.150	57.531	44.450	8.0	3.3	355 000	500 000	36 000	51 000	1 900	2 600		
	57.150	57.531	46.038	8.0	3.3	390 000	520 000	39 500	53 500	1 900	2 600		
	212.725	66.675	66.675	53.975	7.0	3.3	570 000	810 000	58 000	82 500	1 700	2 200	
	180.975	47.625	48.006	38.100	7.0	3.3	258 000	375 000	26 300	38 500	2 000	2 600	
104.775	180.975	47.625	48.006	38.100	3.5	3.3	258 000	375 000	26 300	38 500	2 000	2 600	
	190.500	47.625	49.212	34.925	3.5	3.3	296 000	465 000	30 000	47 000	1 800	2 400	
	190.500	47.625	49.212	34.925	3.5	3.3	296 000	465 000	30 000	47 000	1 800	2 400	
106.362	165.100	36.512	36.512	26.988	3.5	3.3	195 000	320 000	19 800	33 000	2 000	2 600	
	107.950	158.750	23.020	21.438	15.875	3.5	3.3	102 000	165 000	10 400	16 800	2 000	2 800
		159.987	34.925	34.925	26.988	3.5	3.3	164 000	315 000	16 700	32 000	2 000	2 800
161.925		34.925	34.925	26.988	3.5	3.3	164 000	280 000	16 800	28 600	2 000	2 800	
165.100	36.512	36.512	26.988	3.5	3.3	195 000	320 000	19 800	33 000	2 000	2 600		
	47.625	49.212	34.925	3.5	3.3	296 000	465 000	30 000	47 000	1 800	2 400		
	47.625	49.212	34.925	3.5	3.3	296 000	465 000	30 000	47 000	1 800	2 400		
	212.725	66.675	66.675	53.975	8.0	3.3	570 000	810 000	58 000	82 500	1 700	2 200	
109.987	159.987	34.925	34.925	26.988	3.5	3.3	164 000	315 000	16 700	32 000	2 000	2 800	
	159.987	34.925	34.925	26.988	8.0	3.3	164 000	315 000	16 700	32 000	2 000	2 800	
109.992	177.800	41.275	41.275	30.162	3.5	3.3	232 000	375 000	23 700	38 000	1 800	2 600	
	110.000	165.000	35.000	35.000	26.500	3.0	2.5	195 000	320 000	19 800	33 000	2 000	2 600
180.000		47.000	46.000	38.000	3.0	2.5	310 000	490 000	31 500	50 000	1 900	2 600	
111.125	190.500	47.625	49.212	34.925	3.5	3.3	296 000	465 000	30 000	47 000	1 800	2 400	
	114.300	152.400	21.433	21.433	16.670	1.5	1.5	89 500	178 000	9 100	18 100	2 000	2 800
177.800		41.275	41.275	30.162	3.5	3.3	232 000	375 000	23 700	38 000	1 800	2 600	
180.000		34.925	31.750	25.400	3.5	0.8	174 000	254 000	17 800	25 900	1 800	2 400	
190.500		47.625	49.212	34.925	3.5	3.3	296 000	465 000	30 000	47 000	1 800	2 400	
212.725		66.675	66.675	53.975	7.0	3.3	475 000	700 000	48 500	71 500	1 700	2 400	
212.725	66.675	66.675	53.975	7.0	3.3	570 000	810 000	58 000	82 500	1 700	2 200		
115.087	190.500	47.625	49.212	34.925	3.5	3.3	296 000	465 000	30 000	47 000	1 800	2 400	
	117.475	180.975	34.925	31.750	25.400	3.5	3.3	174 000	254 000	17 800	25 900	1 800	2 400

Bearing Numbers		Abutment and Fillet Dimensions (mm)					Eff. Load Centers (mm) a	Constant e	Axial Load Factors		Mass (kg)			
CONE	CUP	d_a	d_b	D_a	D_b	Cone r_a max.			Y_1	Y_0	approx. CONE	CUP		
52400	52618	117	111	142	152	3.5	3.3	36.1	0.47	1.3	0.69	1.75	0.702	
	52637	117	111	144	154	3.5	3.3	36.1	0.47	1.3	0.69	1.75	0.942	
	687	118	112	149	160	3.5	3.3	38.3	0.47	1.3	0.70	2.15	1.24	
780	772	119	113	161	168	3.5	3.3	39.1	0.39	1.6	0.86	2.88	1.99	
	854	129	114	170	174	8	3.3	41.8	0.33	1.8	0.99	4.13	2.55	
HH 221449	HH 221410	131	116	171	179	8	3.3	42.3	0.33	1.8	0.99	4.55	2.24	
HH 224335	HH 224310	132	121	192	202	7	3.3	47.3	0.33	1.8	1.0	8.14	3.06	
787	772	129	116	161	168	7	3.3	39.1	0.39	1.6	0.86	2.66	1.99	
	782	122	116	161	168	3.5	3.3	39.1	0.39	1.6	0.86	2.68	1.99	
	71412	71750	124	118	171	181	3.5	3.3	40.1	0.42	1.4	0.79	4.0	1.71
		56418	122	116	149	159	3.5	3.3	38.6	0.50	1.2	0.66	1.87	0.861
37425	37625	122	115	143	152	3.5	3.3	37.0	0.61	0.99	0.54	0.886	0.488	
	LM 522546	122	116	146	154	3.5	3.3	33.7	0.40	1.5	0.82	1.65	0.784	
	48190	122	116	146	156	3.5	3.3	38.7	0.51	1.2	0.65	1.59	0.83	
56425	56650	123	117	149	159	3.5	3.3	38.6	0.50	1.2	0.66	1.8	0.861	
	71425	126	120	171	181	3.5	3.3	40.1	0.42	1.4	0.79	3.79	1.71	
	HH 224340	139	126	192	202	8	3.3	47.3	0.33	1.8	1.0	7.58	3.06	
LM 522549	LM 522510	124	118	146	154	3.5	3.3	33.7	0.40	1.5	0.82	1.53	0.784	
	LM 522548	133	118	146	154	8	3.3	33.7	0.40	1.5	0.82	1.53	0.784	
64433	64700	128	121	160	172	3.5	3.3	42.4	0.52	1.2	0.64	2.64	1.11	
	▲ JM 822049	▲ JM 822010	124	119	149	159	3	2.5	38.3	0.50	1.2	0.66	1.64	0.842
▲ JHM 522649		▲ JHM 522610	127	122	162	172	3	2.5	40.9	0.41	1.5	0.81	3.12	1.51
71437	71750	129	123	171	181	3.5	3.3	40.1	0.42	1.4	0.79	3.58	1.71	
	L 623149	L 623110	123	121	143	148	1.5	1.5	27.4	0.41	1.5	0.80	0.725	0.344
64450		131	125	160	172	3.5	3.3	42.4	0.52	1.2	0.64	2.39	1.11	
68450		** 68709	130	123	165	172	3.5	0.8	40.0	0.50	1.2	0.66	1.95	1.0
71450	71750	132	125	171	181	3.5	3.3	40.1	0.42	1.4	0.79	3.37	1.71	
	938	141	128	187	193	7	3.3	46.9	0.33	1.8	1.0	6.01	4.11	
HH 224346	HH 224310	143	131	192	202	7	3.3	47.3	0.33	1.8	1.0	7.01	3.06	
71453	71750	133	126	171	181	3.5	3.3	40.1	0.42	1.4	0.79	3.31	1.71	
	68462	132	125	163	172	3.5	3.3	40.0	0.50	1.2	0.66	1.73	1.05	

Notes ** The maximum outside diameter is listed and its tolerance is negative (See Table 8.4.2 on Pages A68 and A69).

▲ The tolerances are listed in Tables 2, 3 and 4 on Pages B113 and B114.

SINGLE-ROW TAPERED ROLLER BEARINGS (INCH DESIGN)

Bore Diameter 120.000 – 165.100 mm

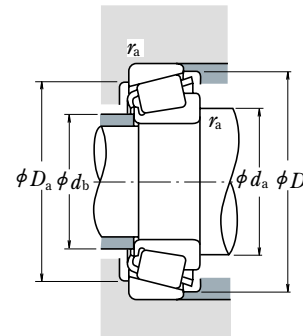
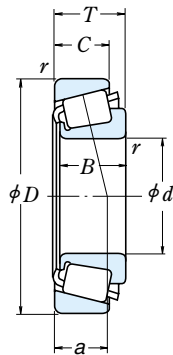

Dynamic Equivalent Load

$$P = X F_r + Y F_a$$

$F_a/F_r \leq e$		$F_a/F_r > e$	
X	Y	X	Y
1	0	0.4	Y_1

Static Equivalent Load

$$P_0 = 0.5 F_r + Y_0 F_a$$

When $F_r > 0.5 F_r + Y_0 F_a$, use $P_0 = F_r$

The values of e , Y_1 , and Y_0 are given in the table below.

d	Boundary Dimensions (mm)					Cone r min.	Cup r	Basic Load Ratings (N)				Limiting Speeds (min ⁻¹)	
	D	T	B	C	C _r			C _{0r}	C _r	C _{0r}	Grease	Oil	
120.000	170.000	25.400	25.400	19.050	3.3	3.3	130 000	219 000	13 200	22 300	1 900	2 600	
	174.625	35.720	36.512	27.783	3.5	1.5	212 000	385 000	21 600	39 000	1 900	2 600	
120.650	182.562	39.688	38.100	33.338	3.5	3.3	228 000	445 000	23 200	45 000	1 800	2 400	
	206.375	47.625	47.625	34.925	3.3	3.3	320 000	530 000	32 500	54 000	1 600	2 200	
123.825	182.562	39.688	38.100	33.338	3.5	3.3	228 000	445 000	23 200	45 000	1 800	2 400	
	125.000	175.000	25.400	25.400	18.288	3.3	3.3	134 000	232 000	13 700	23 600	1 800	2 400
127.000	165.895	18.258	17.462	13.495	1.5	1.5	84 500	149 000	8 650	15 200	1 900	2 600	
	182.562	39.688	38.100	33.338	3.5	3.3	228 000	445 000	23 200	45 000	1 800	2 400	
	196.850	46.038	46.038	38.100	3.5	3.3	315 000	560 000	32 000	57 500	1 700	2 200	
	215.900	47.625	47.625	34.925	3.5	3.3	287 000	495 000	29 300	50 000	1 500	2 000	
	128.588	206.375	47.625	47.625	34.925	3.3	3.3	320 000	530 000	32 500	54 000	1 600	2 200
130.000	206.375	47.625	47.625	34.925	3.5	3.3	320 000	530 000	32 500	54 000	1 600	2 200	
130.175	203.200	46.038	46.038	38.100	3.5	3.3	315 000	560 000	32 000	57 500	1 700	2 200	
	206.375	47.625	47.625	34.925	3.5	3.3	320 000	530 000	32 500	54 000	1 600	2 200	
133.350	177.008	25.400	26.195	20.638	1.5	1.5	124 000	258 000	12 700	26 300	1 800	2 400	
	190.500	39.688	39.688	33.338	3.5	3.3	240 000	485 000	24 500	49 500	1 700	2 200	
	196.850	46.038	46.038	38.100	3.5	3.3	315 000	560 000	32 000	57 500	1 700	2 200	
	215.900	47.625	47.625	34.925	3.5	3.3	287 000	495 000	29 300	50 000	1 500	2 000	
	136.525	190.500	39.688	39.688	33.338	3.5	3.3	216 000	440 000	22 000	45 000	1 700	2 200
139.700	187.325	28.575	29.370	23.020	1.5	1.5	153 000	305 000	15 600	31 500	1 700	2 200	
142.875	215.900	47.625	47.625	34.925	3.5	3.3	293 000	495 000	29 300	50 000	1 500	2 000	
	254.000	66.675	66.675	47.625	7.0	3.3	515 000	830 000	52 500	84 500	1 300	1 800	
	146.050	193.675	28.575	28.575	23.020	1.5	1.5	170 000	355 000	17 300	36 500	1 600	2 200
149.225	236.538	57.150	56.642	44.450	3.5	3.3	455 000	720 000	46 000	73 500	1 400	1 900	
	254.000	66.675	66.675	47.625	7.0	3.3	515 000	830 000	52 500	84 500	1 300	1 800	
	152.400	254.000	66.675	66.675	47.625	7.0	3.3	515 000	830 000	52 500	84 500	1 300	1 800
158.750	225.425	41.275	39.688	33.338	3.5	3.3	240 000	540 000	24 400	55 000	1 400	1 900	
	165.100	247.650	47.625	47.625	38.100	3.5	3.3	345 000	705 000	35 500	71 500	1 300	1 700

Bearing Numbers		Abutment and Fillet Dimensions (mm)				Cone r _a max.	Cup r _a max.	Eff. Load Centers (mm) a	Constant e	Axial Load Factors		Mass (kg)		
CONE	CUP	d _a	d _b	D _a	D _b					Y ₁	Y ₀	approx. CONE	CUP	
▲ JL 724348	▲ JL 724314	132	127	156	163	3.3	3.3	32.9	0.46	1.3	0.72	1.08	0.591	
	* M 224748	M 224710	135	129	163	168	3.5	1.5	32.2	0.33	1.8	0.99	1.9	0.866
48282	48220	136	133	168	176	3.5	3.3	34.2	0.31	2.0	1.1	2.56	1.14	
	795	792	139	134	186	198	3.3	3.3	45.7	0.46	1.3	0.72	4.44	1.9
48286	48220	139	133	168	176	3.5	3.3	34.2	0.31	2.0	1.1	2.37	1.14	
	▲ JL 725346	▲ JL 725316	138	133	161	168	3.3	3.3	34.3	0.48	1.3	0.69	1.19	0.573
LL 225749	LL 225710	135	132	158	160	1.5	1.5	24.2	0.33	1.8	0.99	0.647	0.288	
	48290	48220	141	135	168	176	3.5	3.3	34.2	0.31	2.0	1.1	2.19	1.14
	67388	67322	144	138	180	189	3.5	3.3	39.7	0.34	1.7	0.96	3.74	1.46
	74500	74850	148	141	196	208	3.5	3.3	48.4	0.49	1.2	0.68	4.92	1.99
	799	792	146	140	186	198	3.3	3.3	45.7	0.46	1.3	0.72	3.86	1.9
797	792	148	141	186	198	3.5	3.3	45.7	0.46	1.3	0.72	3.76	1.9	
67389	67320	146	141	183	191	3.5	3.3	39.7	0.34	1.7	0.96	3.51	2.06	
	799 A	792	148	142	186	198	3.5	3.3	45.7	0.46	1.3	0.72	3.74	1.9
L 327249	L 327210	143	141	167	171	1.5	1.5	29.5	0.35	1.7	0.95	1.18	0.55	
	48385	48320	148	142	177	184	3.5	3.3	35.9	0.32	1.9	1.0	2.58	1.16
	67390	67322	149	143	180	189	3.5	3.3	39.7	0.34	1.7	0.96	3.27	1.46
	74525	74850	152	146	196	208	3.5	3.3	48.4	0.49	1.2	0.68	4.44	1.99
	48393	48320	151	144	177	184	3.5	3.3	35.9	0.32	1.9	1.0	2.31	1.16
74537	74856	155	148	197	210	3.5	3.3	48.4	0.49	1.2	0.68	4.19	2.13	
LM 328448	LM 328410	149	147	176	182	1.5	1.5	31.7	0.36	1.7	0.93	1.59	0.67	
	74550	74850	158	151	196	208	3.5	3.3	48.4	0.49	1.2	0.68	3.93	1.99
	99550	99100	170	156	227	238	7	3.3	55.3	0.41	1.5	0.81	9.99	3.83
48685	48620	158	151	185	193	3.5	3.3	37.6	0.34	1.8	0.98	2.63	1.19	
	36690	36620	155	154	182	188	1.5	1.5	33.5	0.37	1.6	0.90	1.64	0.725
HM 231140	HM 231110	164	160	217	224	3.5	3.3	45.9	0.32	1.9	1.0	6.07	2.93	
	99575	99100	175	162	227	238	7	3.3	55.3	0.41	1.5	0.81	9.24	3.83
99587	99100	178	165	227	238	7	3.3	55.3	0.41	1.5	0.81	8.86	3.83	
	99600	99100	181	167	227	238	7	3.3	55.3	0.41	1.5	0.81	8.46	3.83
46780	46720	176	169	209	218	3.5	3.3	44.3	0.38	1.6	0.86	3.69	1.66	
	67780	67720	185	179	229	240	3.5	3.3	52.4	0.44	1.4	0.75	5.83	2.33

Notes * The maximum bore diameter is listed and its tolerance is negative (See Table 8.4.1 on Page A68).

▲ The tolerances are listed in Tables 2, 3 and 4 on Pages B113 and B114.

SINGLE-ROW TAPERED ROLLER BEARINGS (INCH DESIGN)

Bore Diameter 170.000 – 206.375 mm

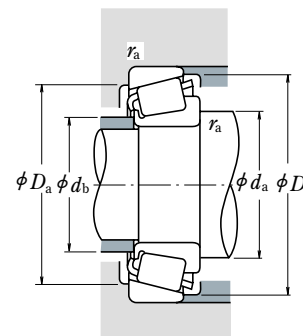
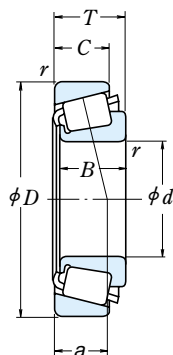

Dynamic Equivalent Load

$$P = XF_r + YF_a$$

$F_a/F_r \leq e$		$F_a/F_r > e$	
X	Y	X	Y
1	0	0.4	Y_1

Static Equivalent Load

$$P_0 = 0.5F_r + Y_0F_a$$

When $F_r > 0.5F_r + Y_0F_a$, use $P_0 = F_r$

The values of e , Y_1 , and Y_0 are given in the table below.

d	Boundary Dimensions (mm)					Cone r min.	Cup r max.	Basic Load Ratings (N)				Limiting Speeds (min^{-1})	
	D	T	B	C	C_r			C_{0r}	C_r	C_{0r}	Grease	Oil	
170.000	230.000	39.000	38.000	31.000	278 000	3.0	2.5	520 000	28 300	53 000	1 300	1 800	
	240.000	46.000	44.500	37.000	380 000	3.0	2.5	720 000	39 000	73 000	1 300	1 800	
174.625	247.650	47.625	47.625	38.100	345 000	3.5	3.3	705 000	35 500	71 500	1 300	1 700	
177.800	227.012	30.162	30.162	23.020	181 000	1.5	1.5	415 000	18 500	42 000	1 300	1 800	
	247.650	47.625	47.625	38.100	345 000	3.5	3.3	705 000	35 500	71 500	1 300	1 700	
	260.350	53.975	53.975	41.275	455 000	3.5	3.3	835 000	46 500	85 000	1 200	1 700	
190.000	260.000	46.000	44.000	36.500	370 000	3.0	2.5	730 000	38 000	74 500	1 100	1 600	
	266.700	47.625	46.833	38.100	345 000	3.5	3.3	720 000	35 000	73 000	1 100	1 500	
190.500	266.700	47.625	46.833	38.100	345 000	3.5	3.3	720 000	35 000	73 000	1 100	1 500	
200.000	300.000	65.000	62.000	51.000	615 000	3.5	2.5	1 130 000	62 500	116 000	1 000	1 400	
203.200	282.575	46.038	46.038	36.512	365 000	3.5	3.3	800 000	37 500	81 500	1 000	1 400	
	282.575	46.038	46.038	36.512	365 000	3.5	3.3	800 000	37 500	81 500	1 000	1 400	

Bearing Numbers		Abutment and Fillet Dimensions (mm)						Eff. Load Centers (mm) a	Constant e	Axial Load Factors		Mass (kg)	
CONE	CUP	d_a	d_b	D_a	D_b	Cone r_a max.	Cup r_a max.			Y_1	Y_0	approx. CONE	CUP
▲ JHM 534149	▲ JHM 534110	184	178	217	224	3	2.5	43.2	0.38	1.6	0.86	3.1	1.3
▲ JM 734449	▲ JM 734410	185	180	222	232	3	2.5	50.5	0.44	1.4	0.75	4.42	2.02
67787	67720	192	185	229	240	3.5	3.3	52.4	0.44	1.4	0.75	4.88	2.33
36990	36920	189	186	214	221	1.5	1.5	42.9	0.44	1.4	0.75	2.1	0.907
67790	67720	194	188	229	240	3.5	3.3	52.4	0.44	1.4	0.75	4.56	2.33
M 236849	M 236810	195	192	241	249	3.5	3.3	47.5	0.33	1.8	0.99	6.49	2.86
▲ JM 738249	▲ JM 738210	206	200	242	252	3	2.5	56.4	0.48	1.3	0.69	4.73	2.2
67885	67820	209	203	246	259	3.5	3.3	57.9	0.48	1.3	0.69	5.4	2.64
▲ JHM 840449	▲ JHM 840410	223	215	273	289	3.5	2.5	73.1	0.52	1.2	0.63	10.3	5.19
67983	67920	222	216	260	275	3.5	3.3	61.9	0.51	1.2	0.65	6.03	2.82
67985	67920	224	219	260	275	3.5	3.3	61.9	0.51	1.2	0.65	5.66	2.82

Note ▲ The tolerances are listed in Tables 2, 3 and 4 on Pages B113 and B114.